

Aerodynamic Study of Bulk Commodity Tractor Trailers



Trailer Park Boys

Jake Frost

Liam Johnson

Brandon Hilliard

Overview



- Problem Statement
- Scale Model Manufacturing
- Experimental Set-up
- Data Reduction Techniques
- Trailer Drag & Emissions Results
- Conclusions & Recommendations



Problem Statement: Single Trailer



- Test aerodynamic features of existing tractor trailers to document drag coefficients, emissions output, and fuel consumption rates. The 48ft & 53ft Tractor Trailer configurations are:

48-foot Trailer Configurations

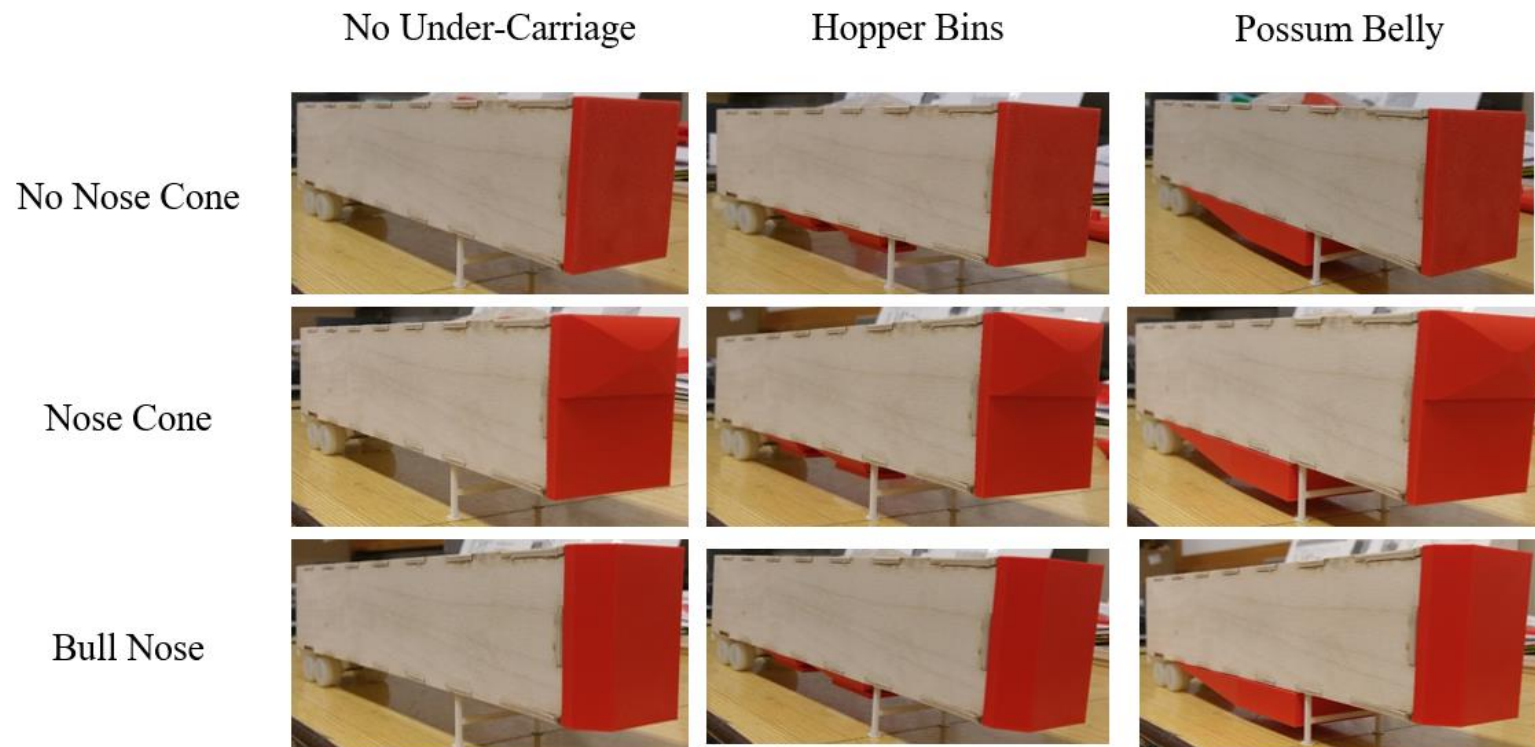

Problem Statement: A-Train



- Test aerodynamic features of existing tractor trailers to document drag coefficients, emissions output, and fuel consumption rates. The A-Train Tractor Trailer configurations are:

A-Train Trailer Configurations

Hopper Bins

No Nose Cone

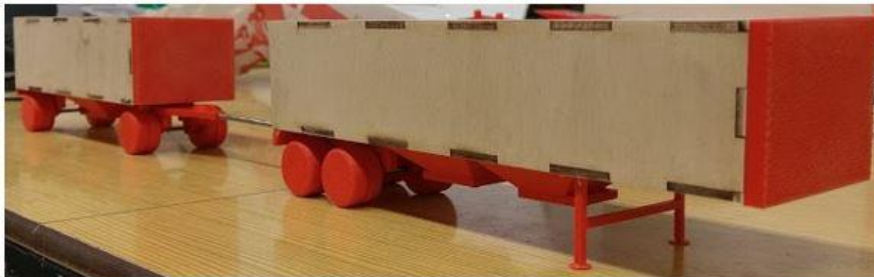

Nose Cone



Full-Size Tongue Length	Model Tongue Length
7'-1"	4.47"
9'-7"	5.26"
14'-1"	6.67"
16'-7"	7.45"
21'-7"	9.02"

Scale Model Part Manufacturing



- 3D-Printing Design Techniques
- Model Accommodations
- Wind Tunnel Accommodations

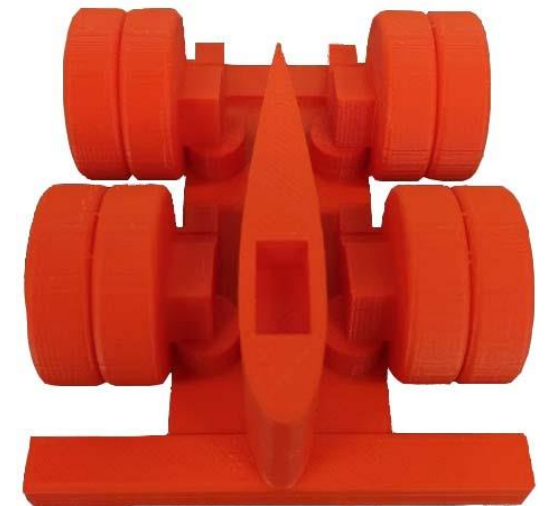
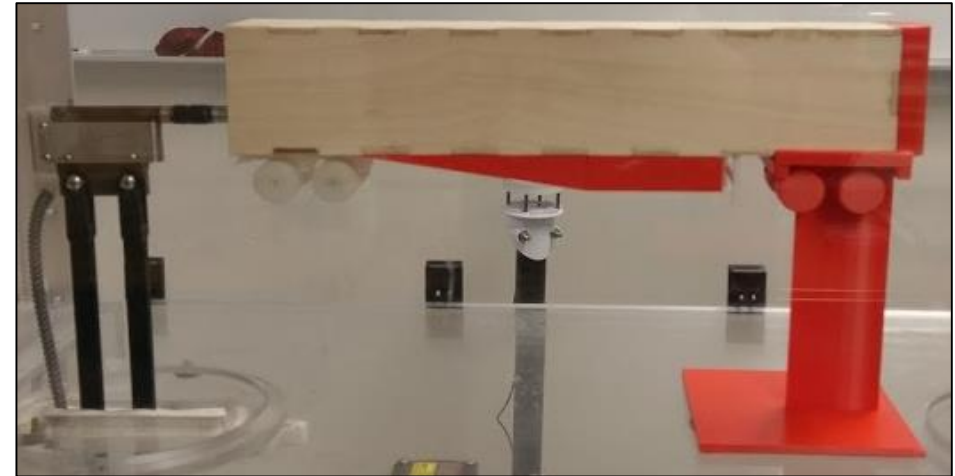

Scale Model Assembly



Number	Feature	Quantity
1	Magnets	12
2	Force Balance Attachment	2
3	Front-End Attachment	7
4	Under-Carriage Attachment	5
5	A-Train Tongue	5
6	Landing Gear	2
7	Wood Panels	15
8	Trailer Axles	6

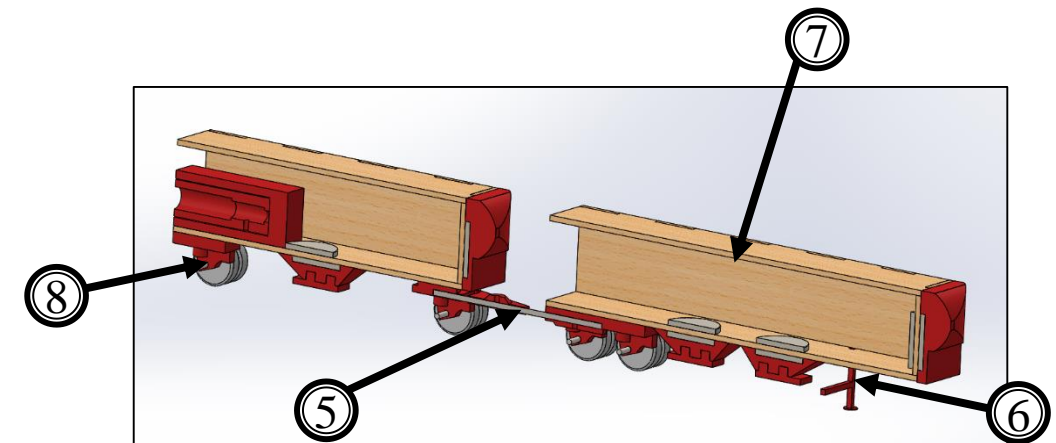
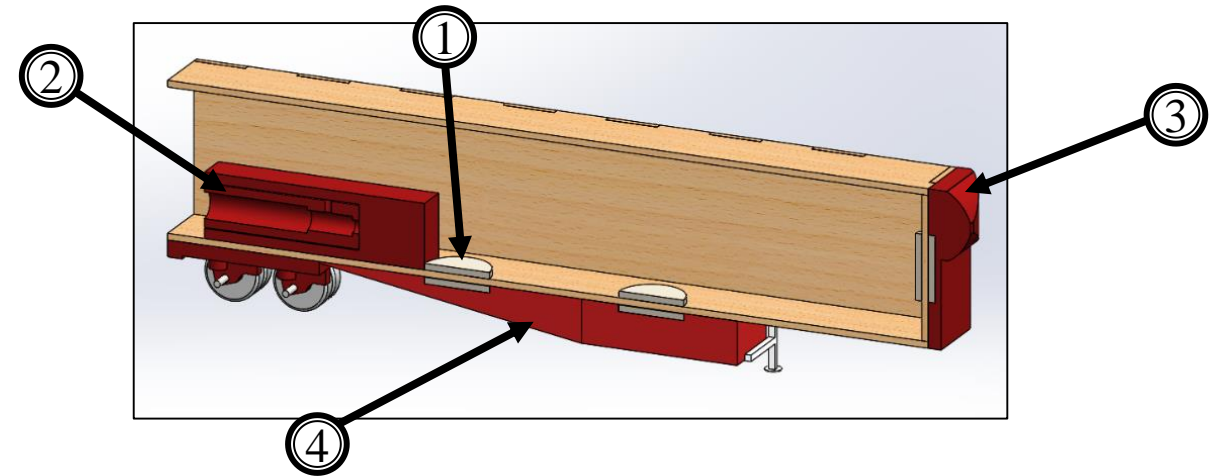

Experimental Set-up



- The trailer models were placed on the force balance within the wind tunnel.
- A level was used to ensure the trailer was straight in the test section.
- All readouts were zeroed before turning on the wind tunnel.

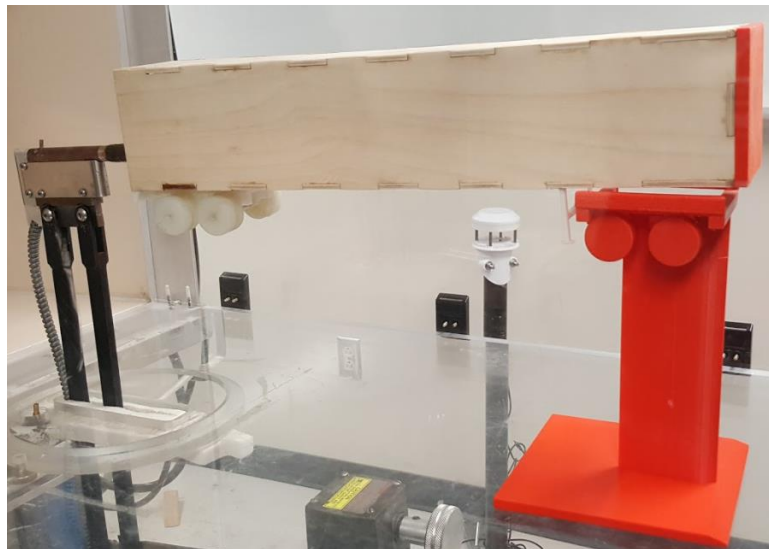

Experimental Testing



- Early testing showed a relatively linear relationship between C_D and wind velocity at higher speeds.
- Future tests were ran from ~30mph to ~78mph.

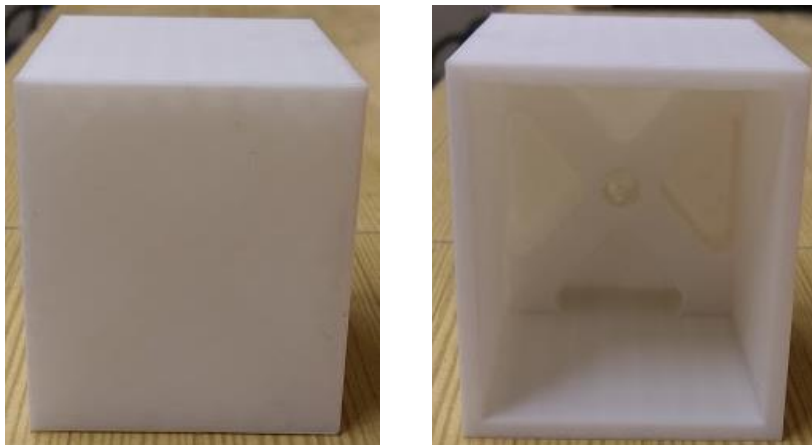

(Test Box Model Used in Preliminary Testing)

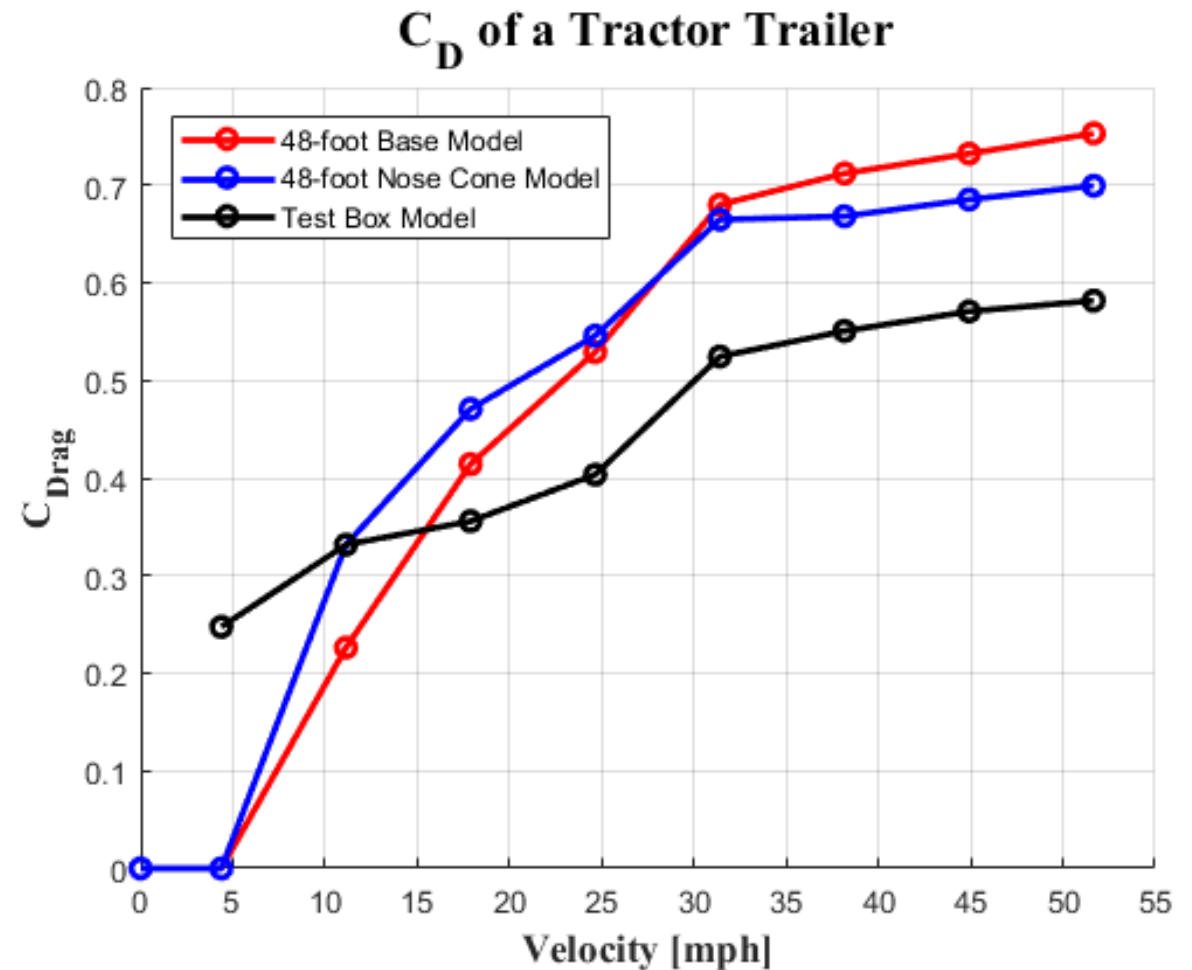

Data Reduction



- Correlate wind speeds to the frequency of the fan driver input.
- Acquire drag force values from the force balance.
- Calculate emissions output (grams of CO₂ per ton-mile).
- Calculate fuel consumption rates (gal of diesel per 1000 ton-miles).

(i)

$$V = 1.2081f - 1.0632$$



(ii)

$$C_D = \frac{F_D}{\frac{1}{2}\rho AV^2}$$



(iii)

$$e_{CO_2} = (C_1 + C_2 \cdot TRRL + C_3 \cdot \Delta C_d A + C_4 \cdot WR) \cdot C_5$$

(CO₂ Emissions Equation)

(iv)

$$FC\left(\frac{gal_{diesel}}{1000\ ton - mile}\right) = \frac{e_{CO_2}\left(\frac{g_{CO_2}}{ton - mile}\right)}{10,180\left(\frac{g_{CO_2}}{gal_{diesel}}\right)} \times 1000$$

(Fuel Consumption Equation)

48-foot Trailer Results

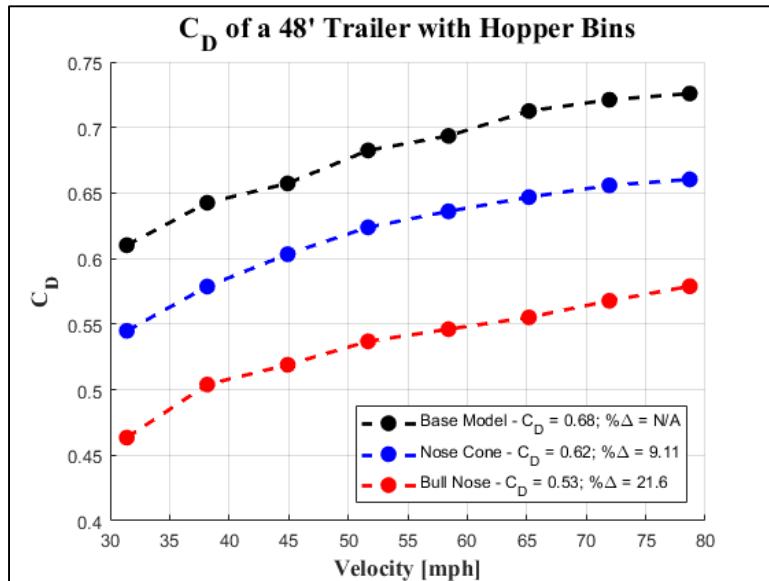

(i)

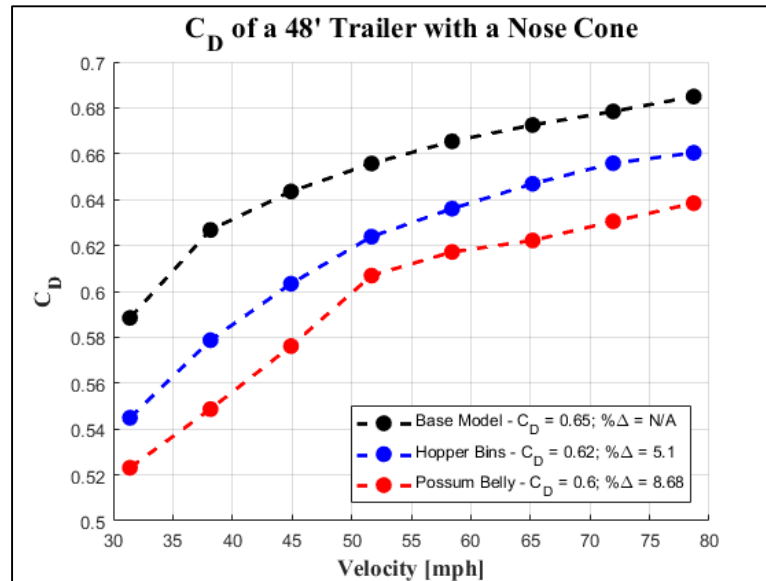

(ii)

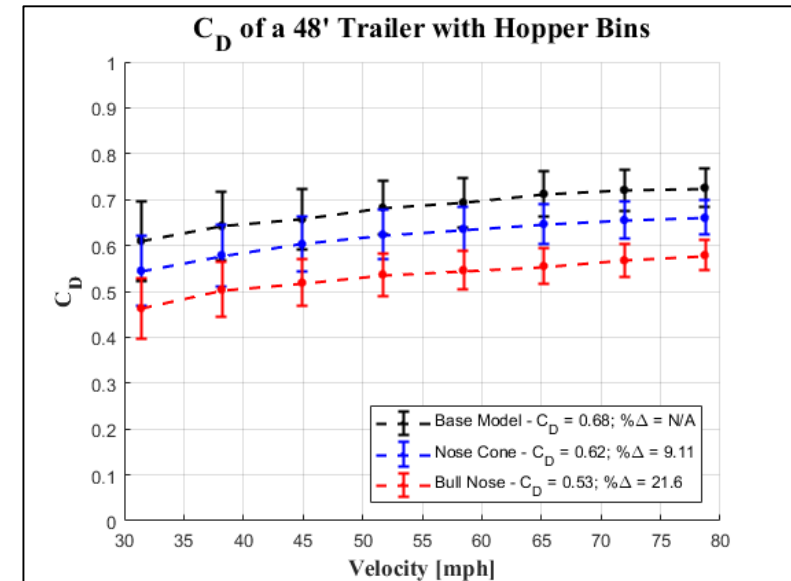

(iii)

- Front-end comparison
- Under-carriage comparison
- Error analysis



A-Train Trailer Results

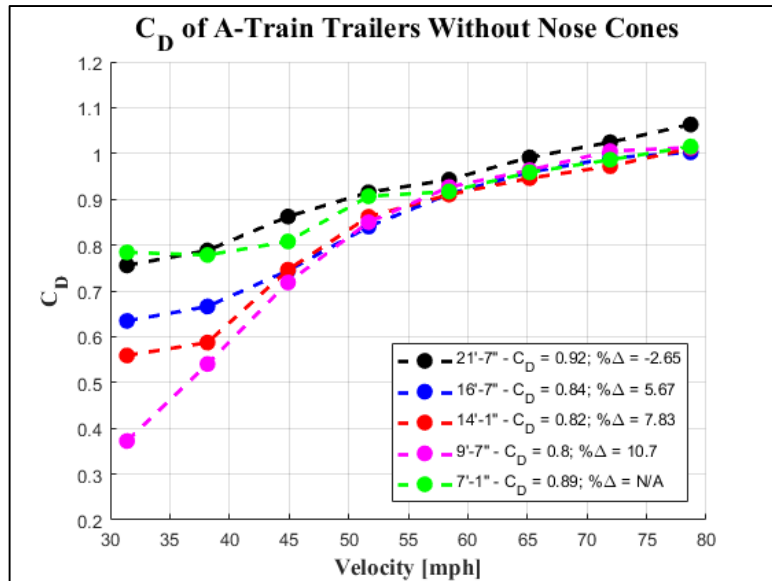

(i)

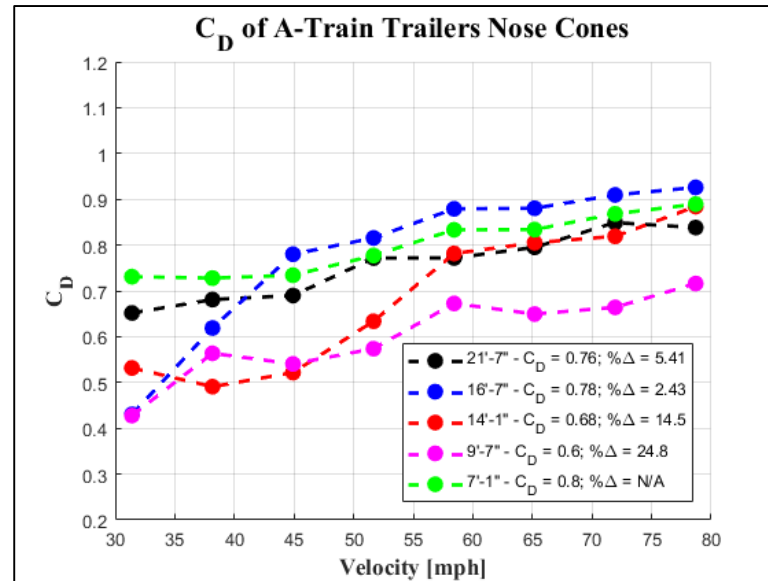

(ii)

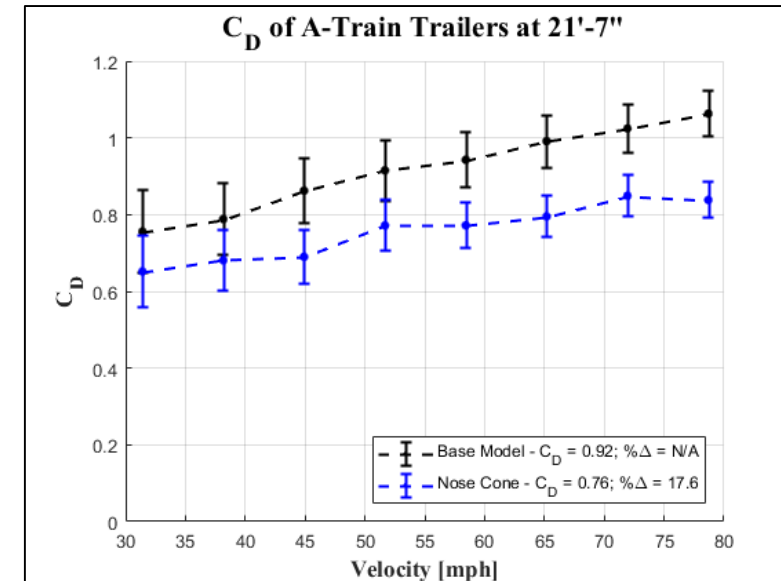

(iii)

- Nose-cone comparison
- Tongue length comparison
- Error analysis



Emissions Predictions



- One ton-mile is one ton of material carried one mile.
- Calculations are based off models with the worst drag coefficients.

Emissions Output (g-CO ₂ /ton-mile)					
48-foot Trailer			A-Train Trailer		
No Nose Cone	No UnderCarriage	N/A	No Nose Cone	7'-1"	123.2
	Hopper Bins	122.7		9'-7"	118.7
	Possum Belly	81.1		14'-1"	119.9
Nose Cone	No UnderCarriage	120.7		16'-7"	120.8
	Hopper Bins	118.4		21'-7"	N/A
	Possum Belly	78.5		Nose Cone	7'-1"
Bull Nose	No UnderCarriage	114.2	9'-7"		109.4
	Hopper Bins	112.6	14'-1"		113.3
	Possum Belly	74.7	16'-7"		117.8
			21'-7"	116.7	

Table 1 of § 1037.107—Phase 2 CO₂ Standards for Full-Aero Box Vans (g/ton-mile)

Model Year	Dry Van	
	Short	Long
2018-2020	125.4	81.3
2021-2023	123.7	78.9
2024-2026	120.9	77.2
2027+	118.8	75.7



Fuel Consumption Predictions

- One ton-mile is one ton of material carried one mile.
- Calculations are based off models with the worst drag coefficients.

Fuel Consumption Rates (Gal-diesel/1000 ton-miles)					
48-foot Trailer			A-Train Trailer		
No Nose Cone	No UnderCarriage	N/A	No Nose Cone	7'-1"	12.10080
	Hopper Bins	12.05120		9'-7"	11.65970
	Possum Belly	7.97010		14'-1"	11.77800
Nose Cone	No UnderCarriage	11.85640	Nose Cone	16'-7"	11.86700
	Hopper Bins	11.63150		21'-7"	N/A
	Possum Belly	7.71150		7'-1"	11.66310
Bull Nose	No UnderCarriage	11.21530	Nose Cone	9'-7"	10.74780
	Hopper Bins	11.05710		14'-1"	11.12840
	Possum Belly	7.34110		16'-7"	11.57360
				21'-7"	11.46340

TABLE 15—PHASE 2 FULL AERO BOX VAN FUEL CONSUMPTION STANDARDS
[Gallons per 1,000 ton-miles]

Model years	Dry van	
	Long	Short
Voluntary Standards		
2018 to 2020	7.98625	12.31827
Mandatory Standards		
2021 to 2023	7.75049	12.15128
2024 to 2026	7.58350	11.87623
2027 and later	7.43615	11.72888

Conclusions



- $C_D = 0.506$ for a 53-foot trailer is with a bull nose and a possum belly.



- $C_D = 0.601$ for an A-Train trailer setup is with a nose cone and an extended tongue length of 9'-7".



Recommendations



- A truck in front of the trailers within the wind tunnel would produce different results.
- An analysis of the skin friction drag that our models produce should be done.

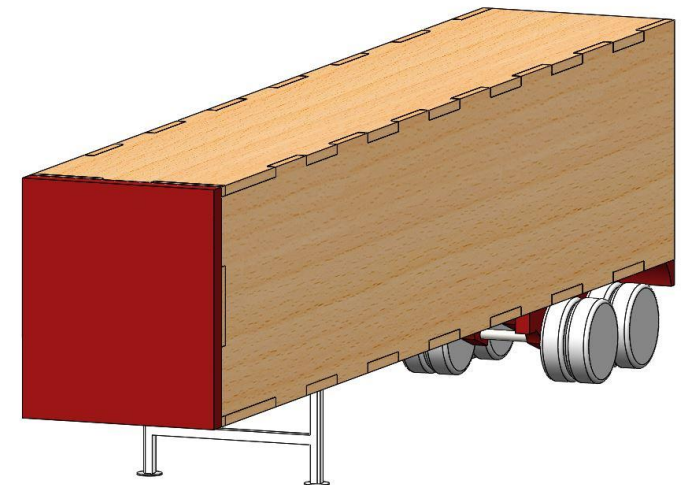
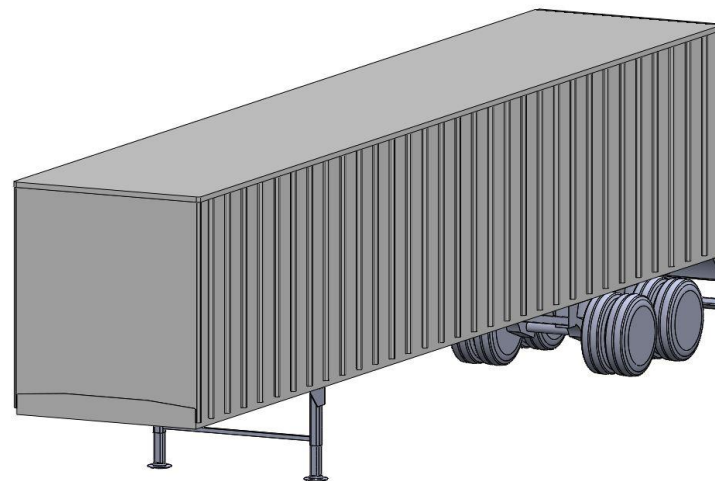
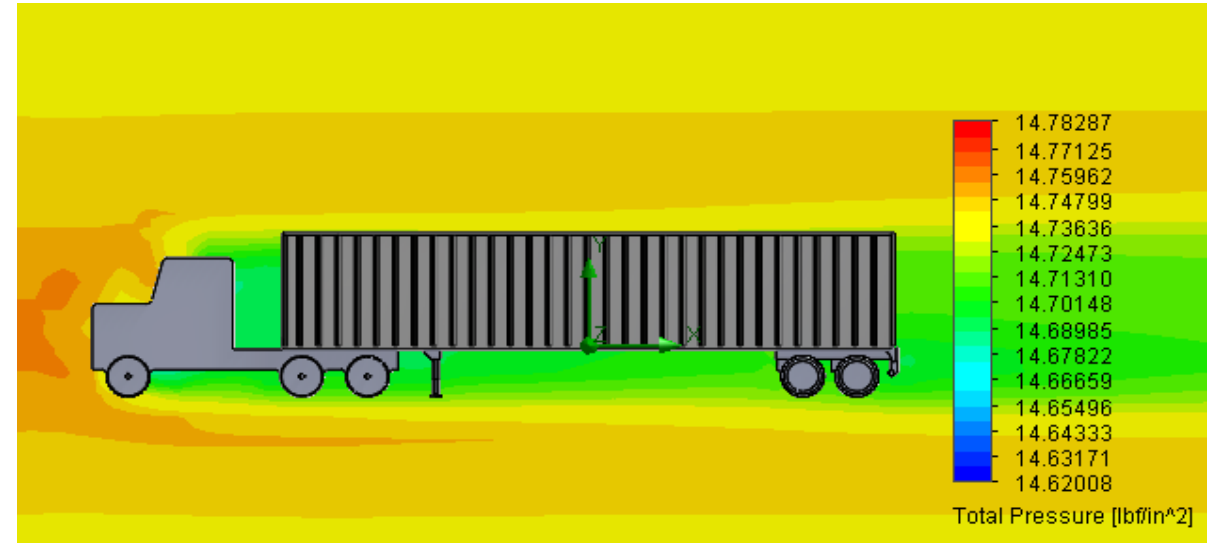

Questions/Comments/Concerns?

