



University
of Idaho

BIOCHAR PRODUCTION SYSTEM

JAKE HALL – ME

ADAM O'KEEFFE – BE

RACHEL ROSASCO – BE

WILL SEEGMILLER – ME

JOE STANLEY – EE

PROBLEM STATEMENT

- An abundance of biomass exists in the region as a byproduct of industrial lumber production
 - Material has little value and is currently being used primarily for steam generation.
- Farmers around the Palouse are struggling with topsoil degradation, erosion, water retention, and nutrient loss.



TEAM MISSION STATEMENT

Our team's mission is to develop and prototype a model of a scalable, practical retrofit for modern, industrial boilers that will produce biochar for sale and heat energy. This design must account for multiple variables and allow control of input and output flow rates amongst other factors.



PROJECT LEARNING

HISTORY OF BIOCHAR

- Biochar dates back 2,000 years to a civilization in a remote region of the Amazon Basin where dark, highly fertile soil has been discovered.
- It is theorized that the ancient Amazonians used a process known as “slash and char”, where the biomass (plant material) were cut, ignited and buried to smolder.
- This process allowed the Amazonians to support a diverse agriculture and explains how their population grew to immense numbers

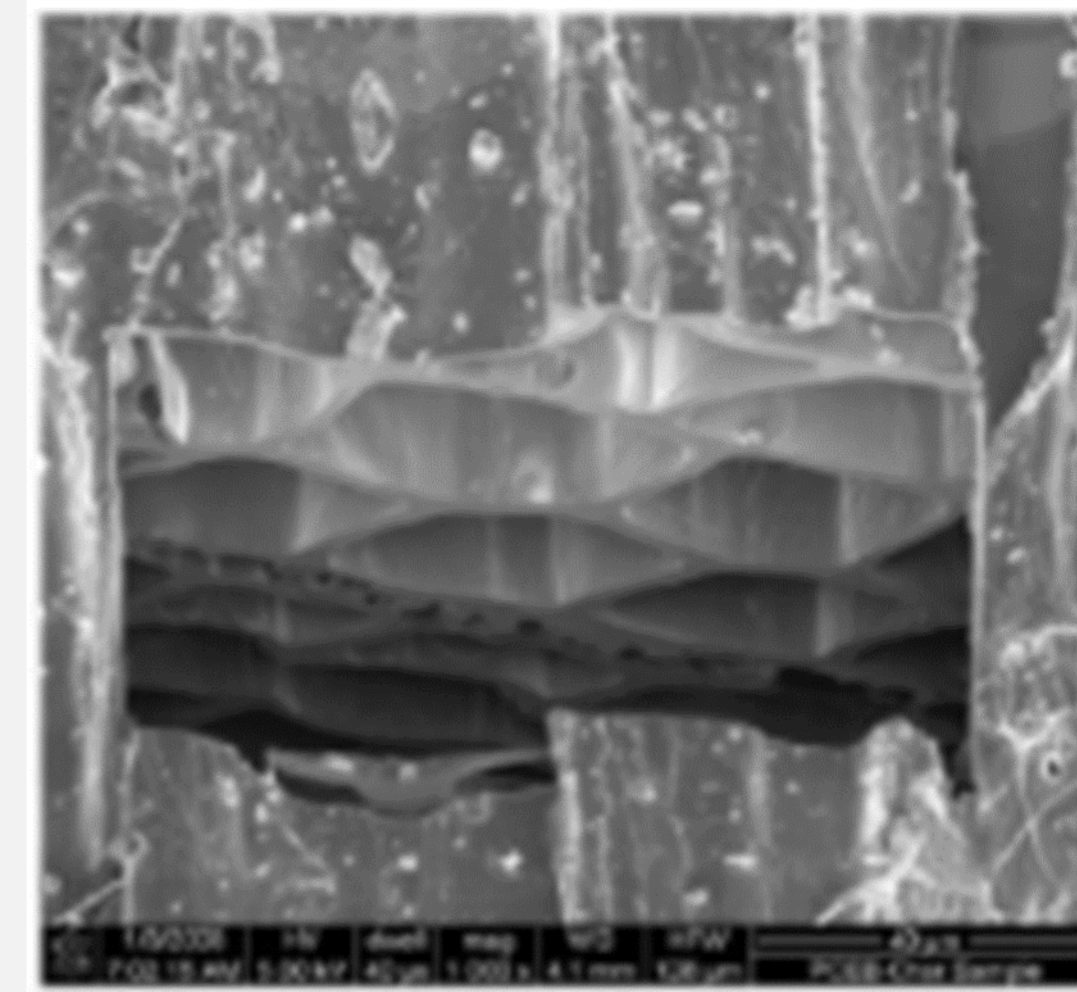

Pine wood biochar

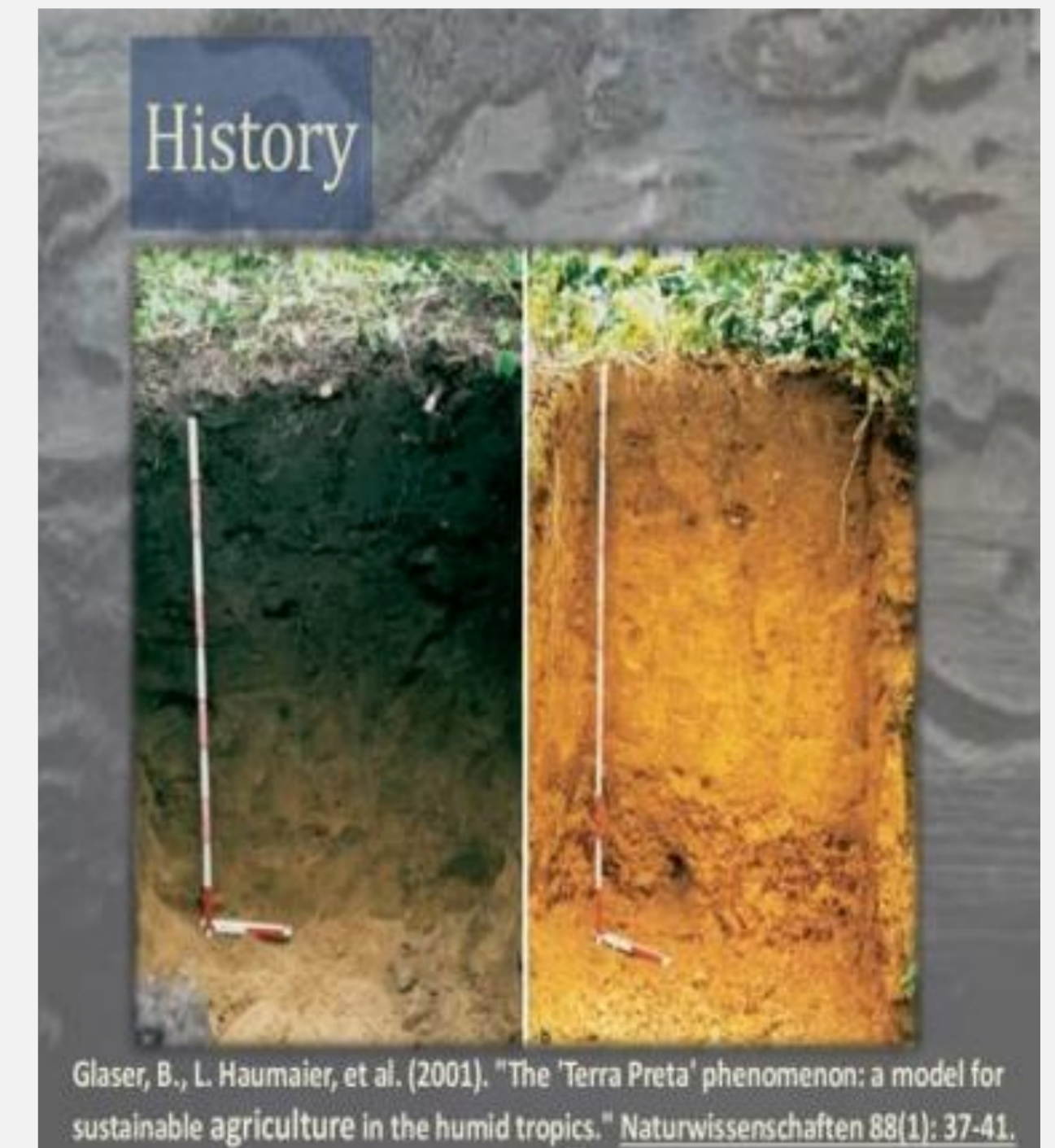

Soil profile

BENEFITS OF BIOCHAR

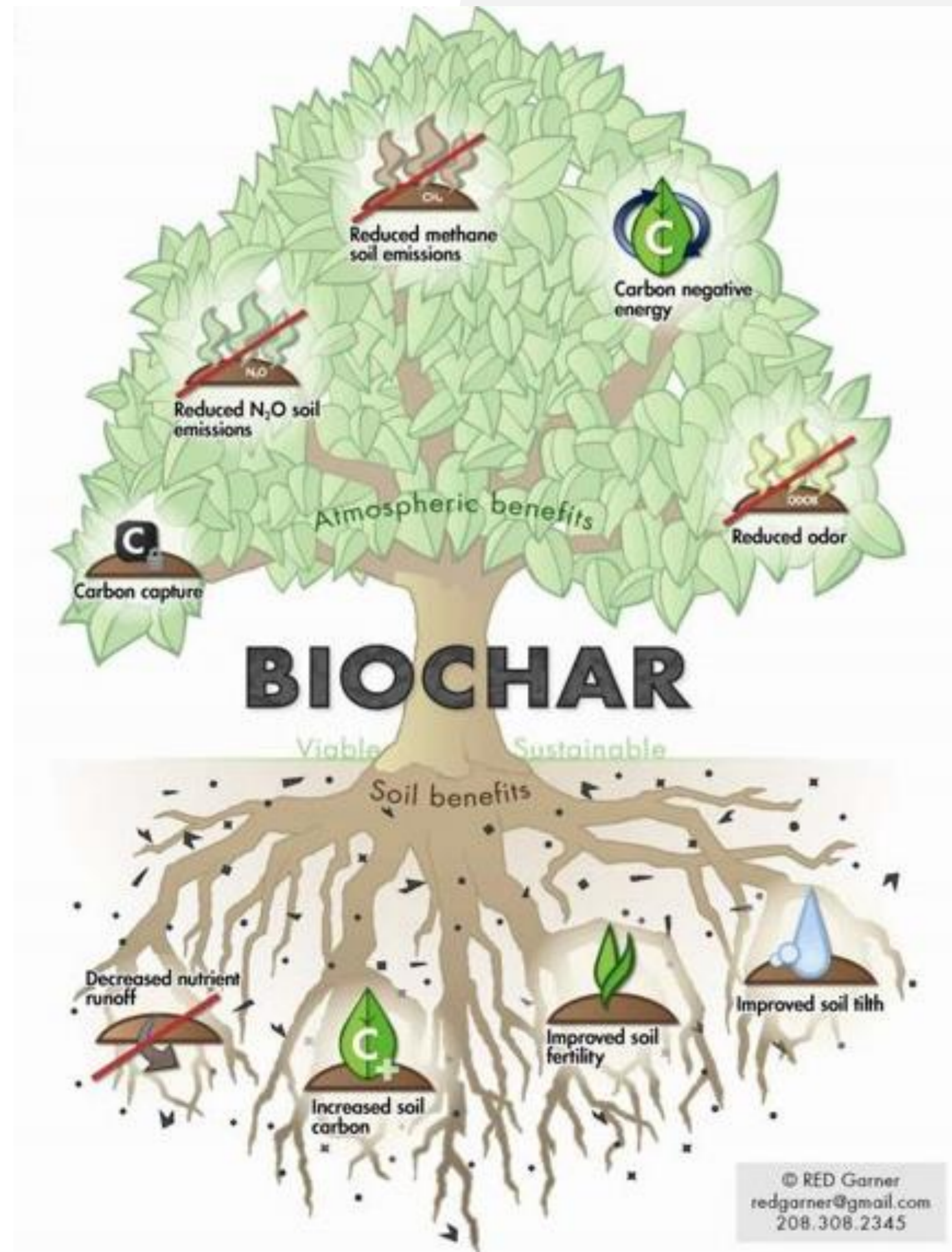

- Rich in fixed carbon
- Enhanced surface area caused by micro and macro pores
- Easily absorbs and maintains moisture and nutrients.
- Acts as filter to absorb contaminants in rainwater and storm water runoff.
- Increases soil fertility
- Reduces need for some chemical and fertilizer inputs

BIOMASS RESOURCES IN THE NORTHWEST

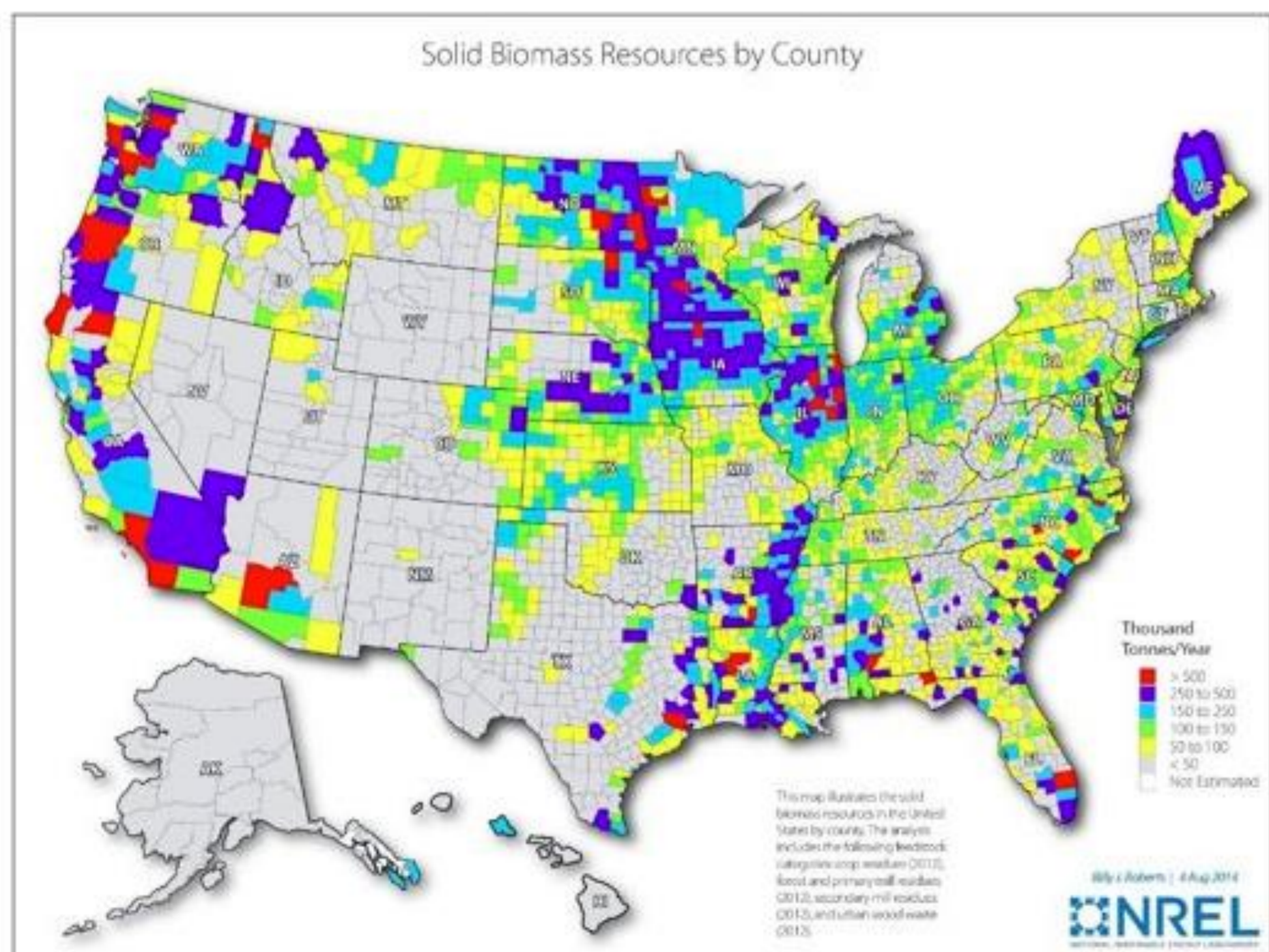

https://www.nrel.gov/gis/images/biomass_2014/national_biomass_solid_total_2014-01.jpg

- The National Renewable Energy Laboratory estimates that in 2012 over 6,000,000 tons of waste biomass were produced in area surrounding Moscow (150 mi. radius).
- 1,750,000 tons were from primary mill residues.
- 2,250,000 tons were from crop residues.

BOILER SYSTEM INTEGRATION

- Lumber mills have a pre-existing boiler that is already being used to generate steam
- Flue gas comes off of the boiler at extremely high temperatures
- Would not need to add any extra energy to pyrolyze waste wood chips



DESIGNS

NEEDS AND CONSTRAINTS

- Continuous process
- Easily integrated to a boiler system
- Scalable industrial design
- Energy efficient design
- Dynamic control system
- Heat exchanger

DESIGN MODEL

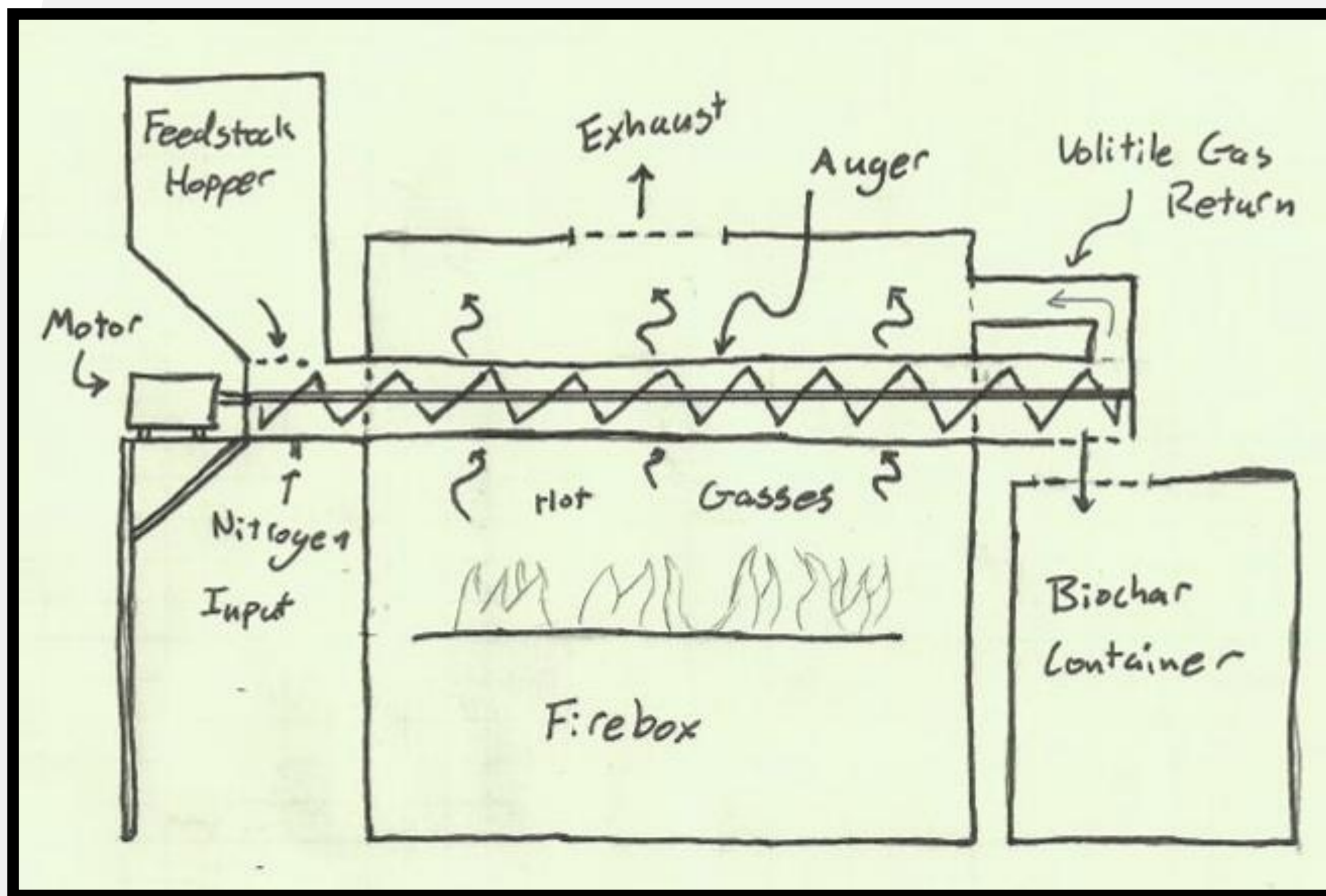

DESIGN MODEL

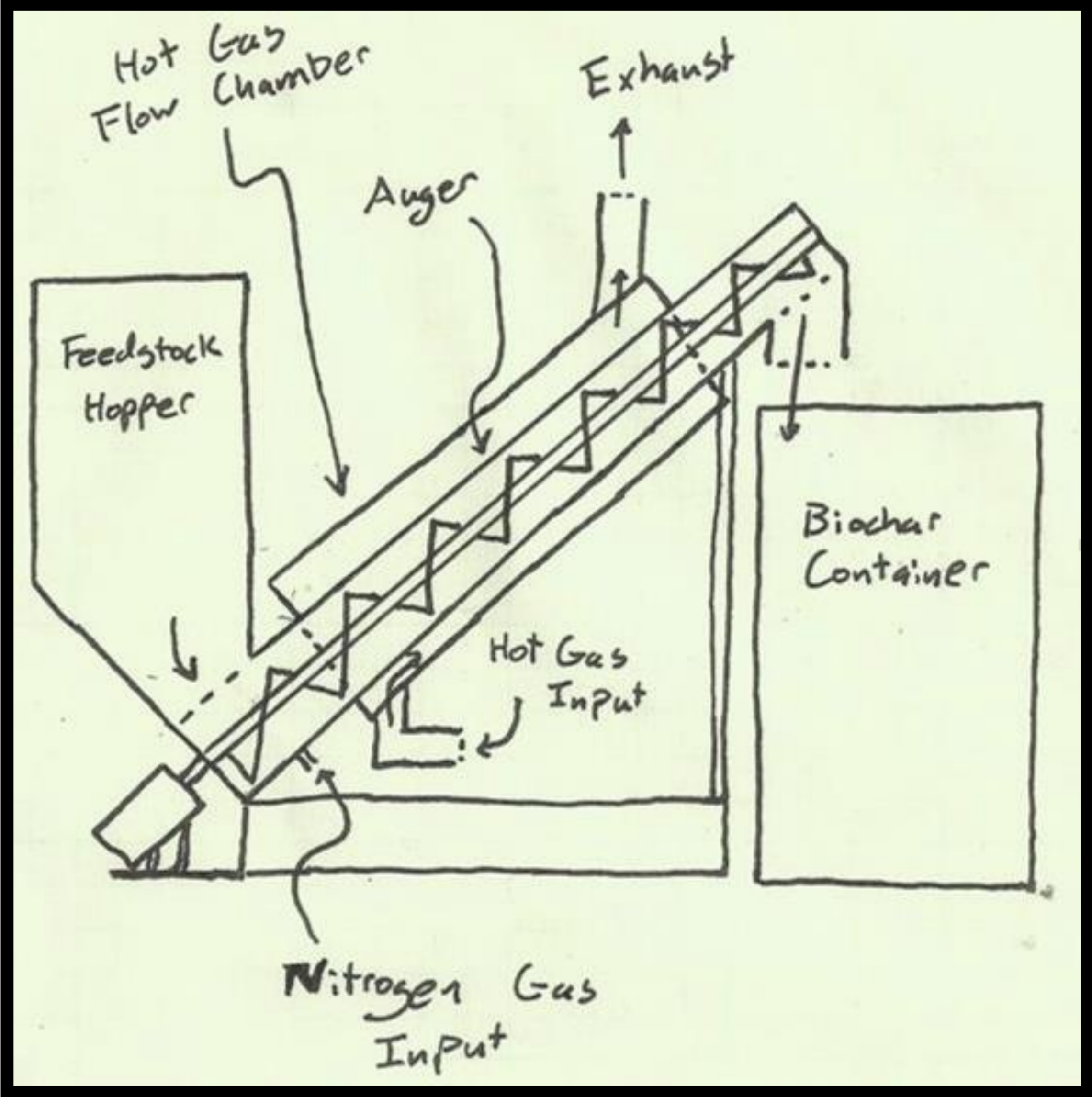
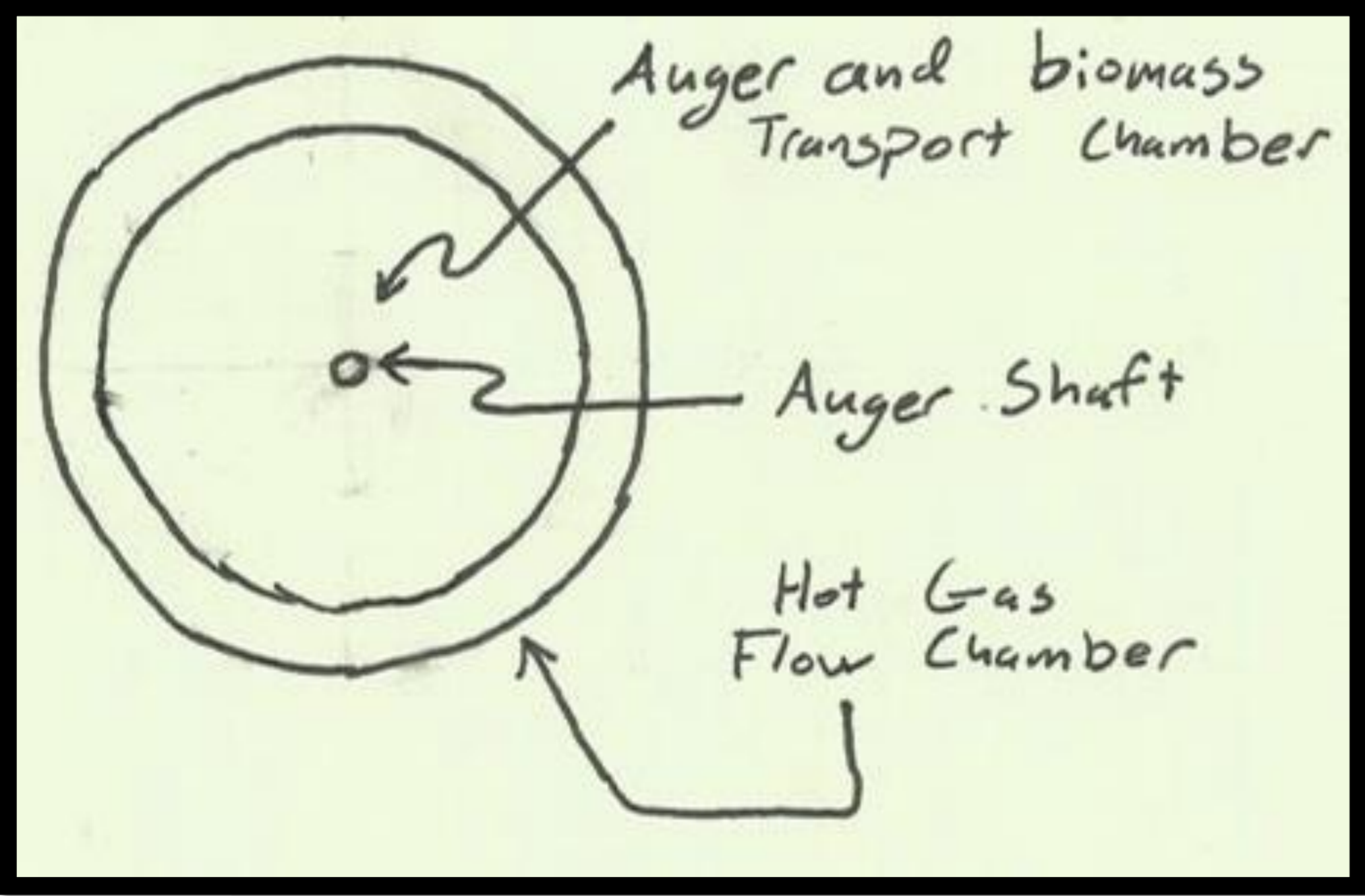

DESIGN MODEL

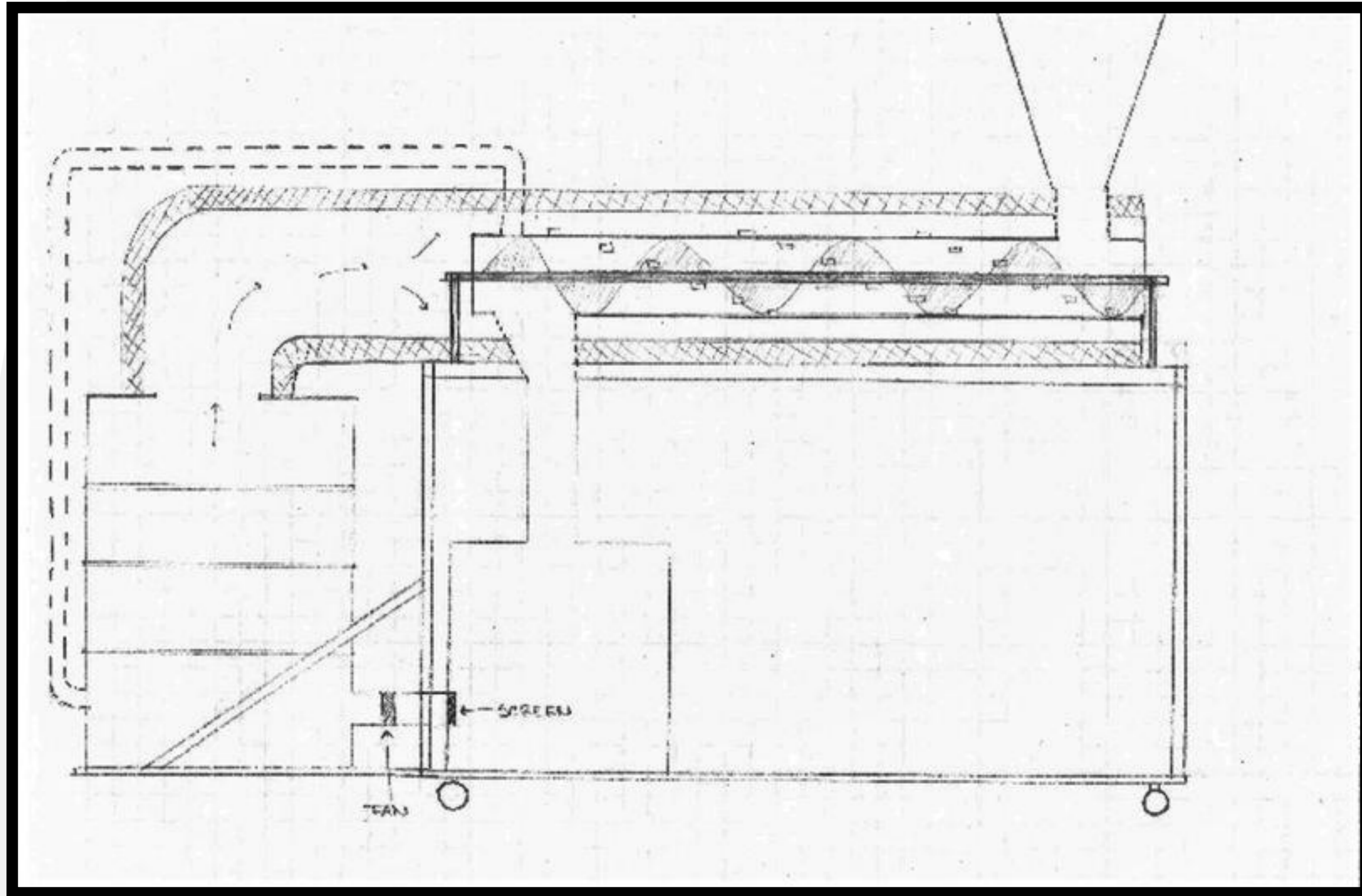

DESIGN RENDER

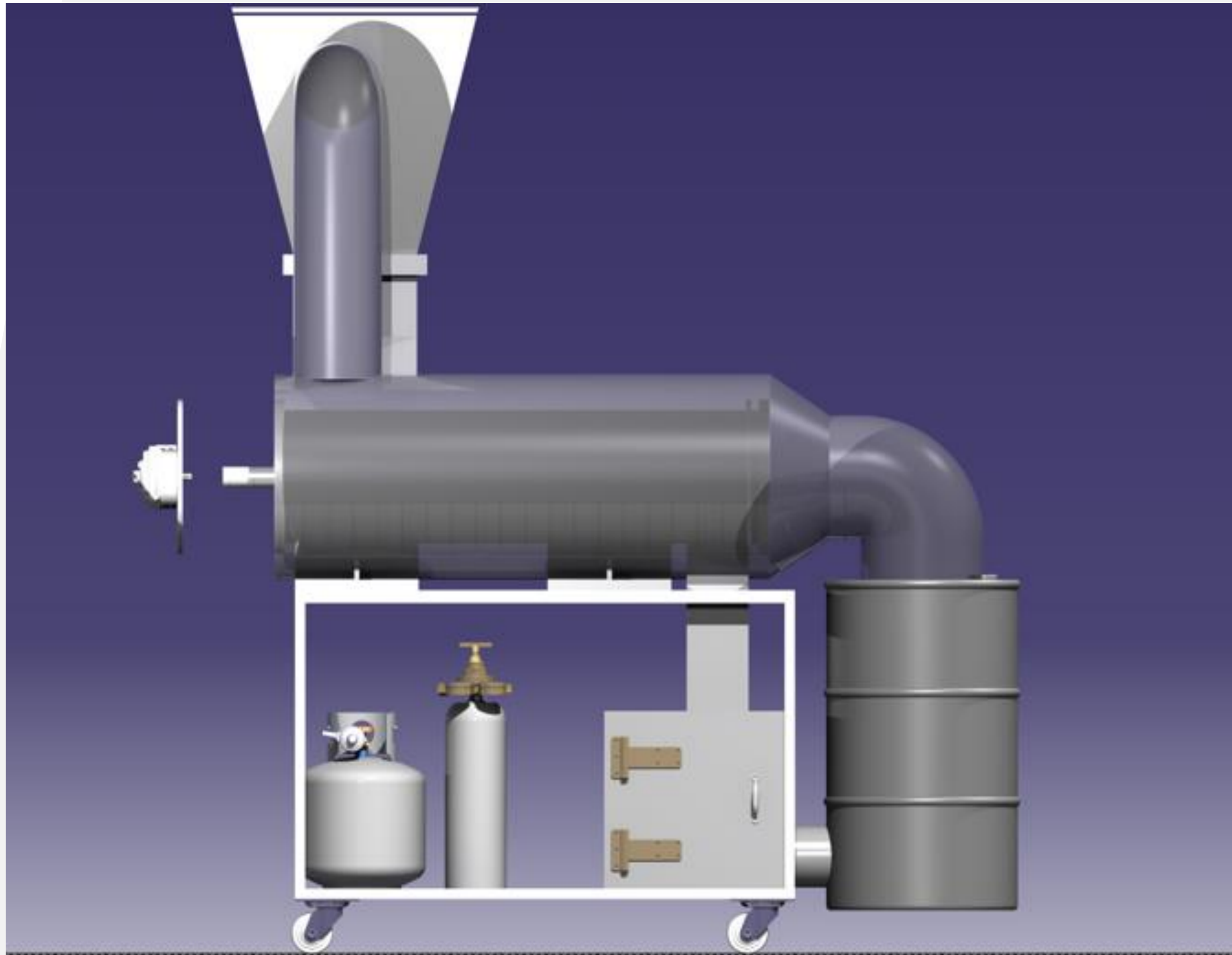

DESIGN RENDER

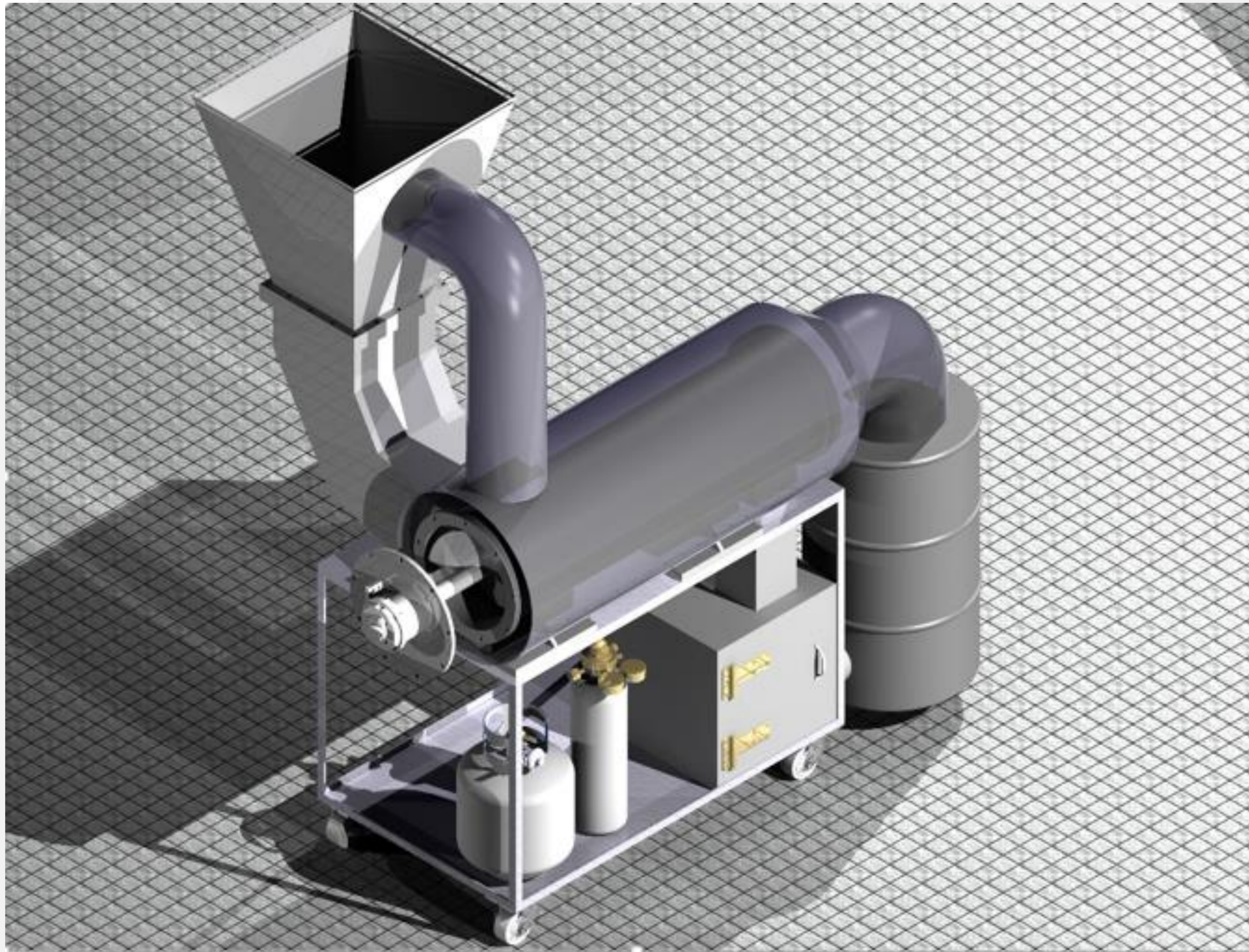

DESIGN RENDER





ELECTRONICS



CONTROL SYSTEM

Programmable Logic Controller – Productivity P-2000 by Automation Direct

- Master control unit for attached VFDs and subsequent 1- and 3-phase motors
- Central data logging
- Built in system automation and demo
- Emergency shutoff and lockout

Sensory Feedback and Monitoring

- Boiler, auger, and collector temperature
- Boiler visible flame detection
- Oxygen monitoring

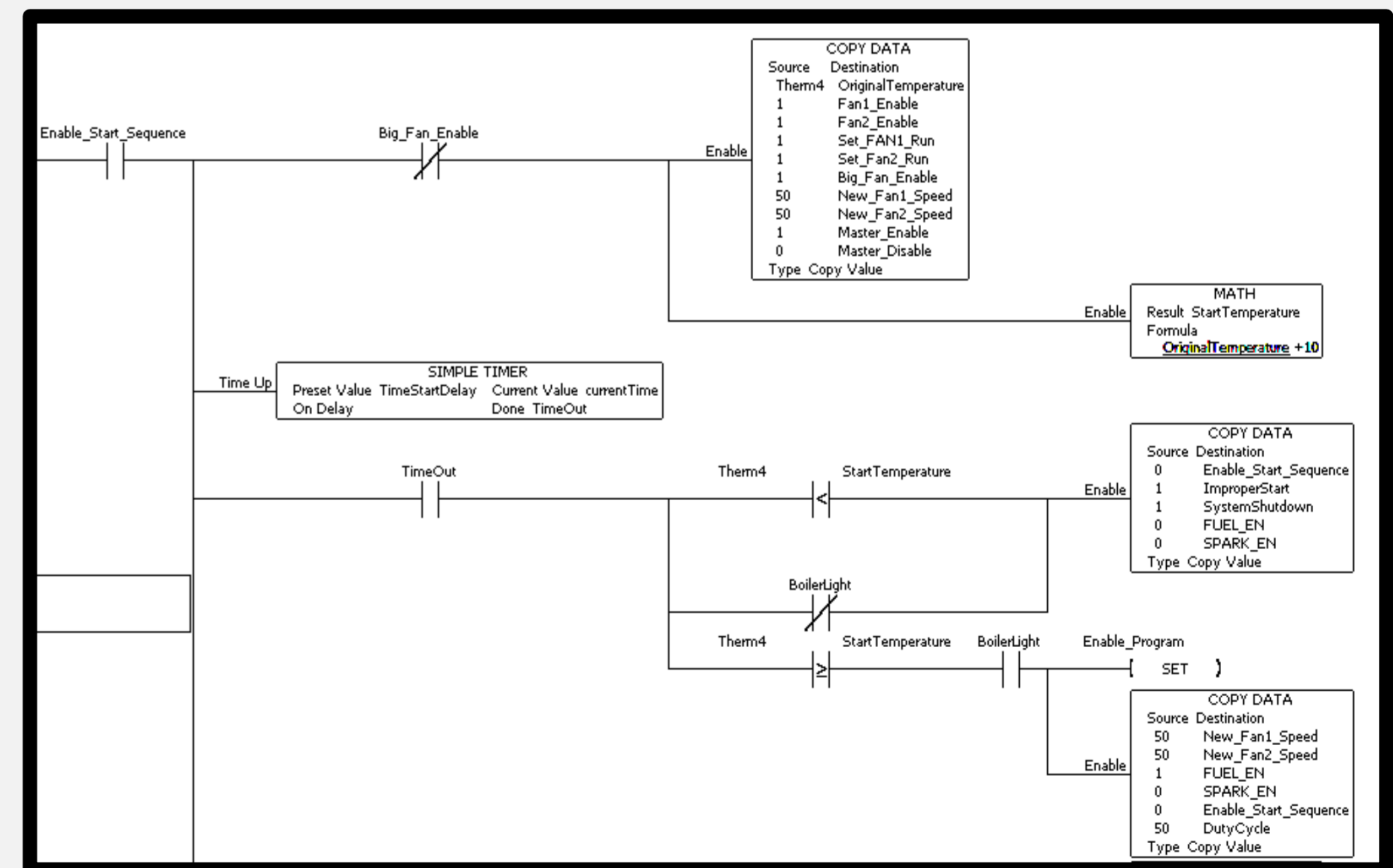

USER INTERFACE

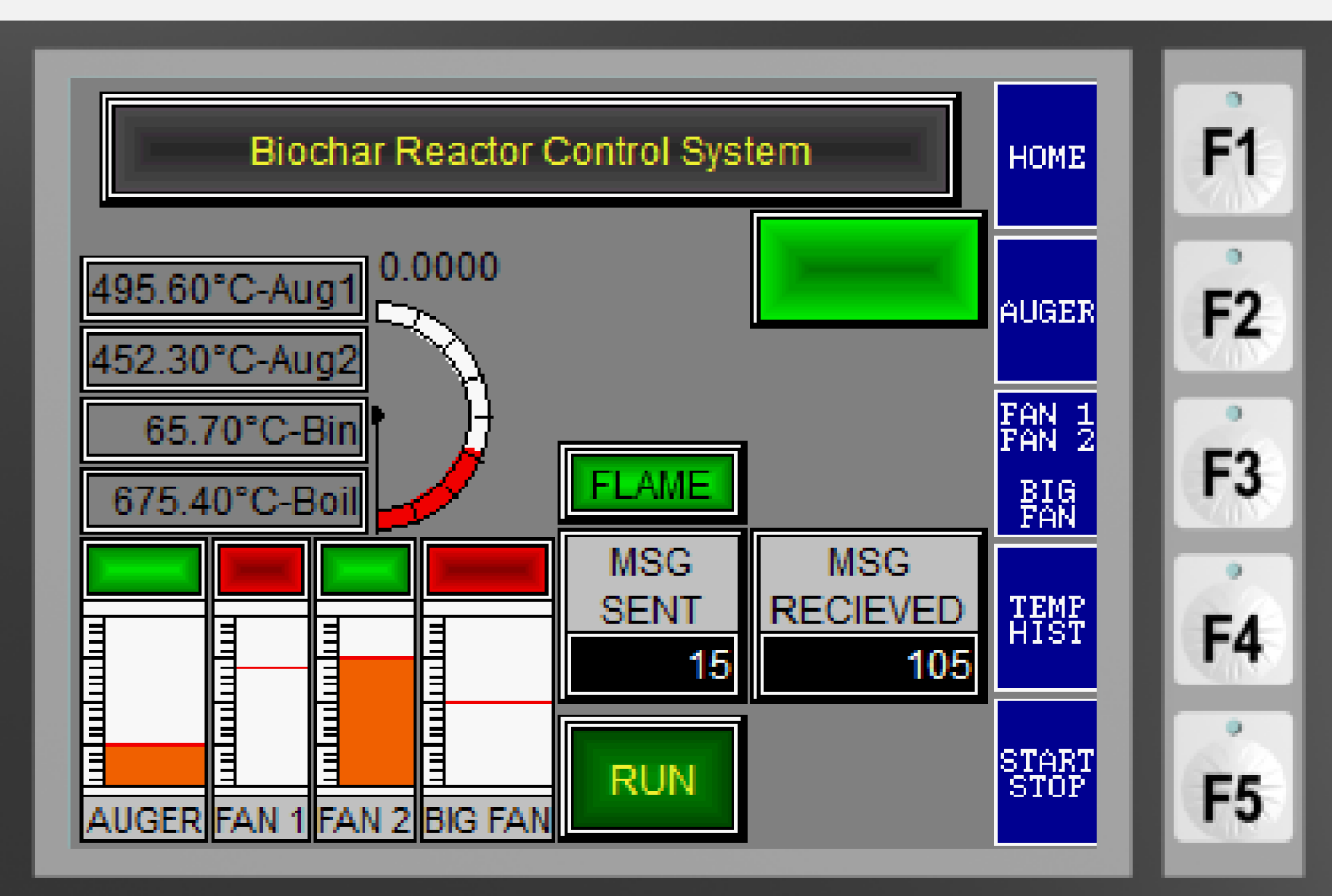
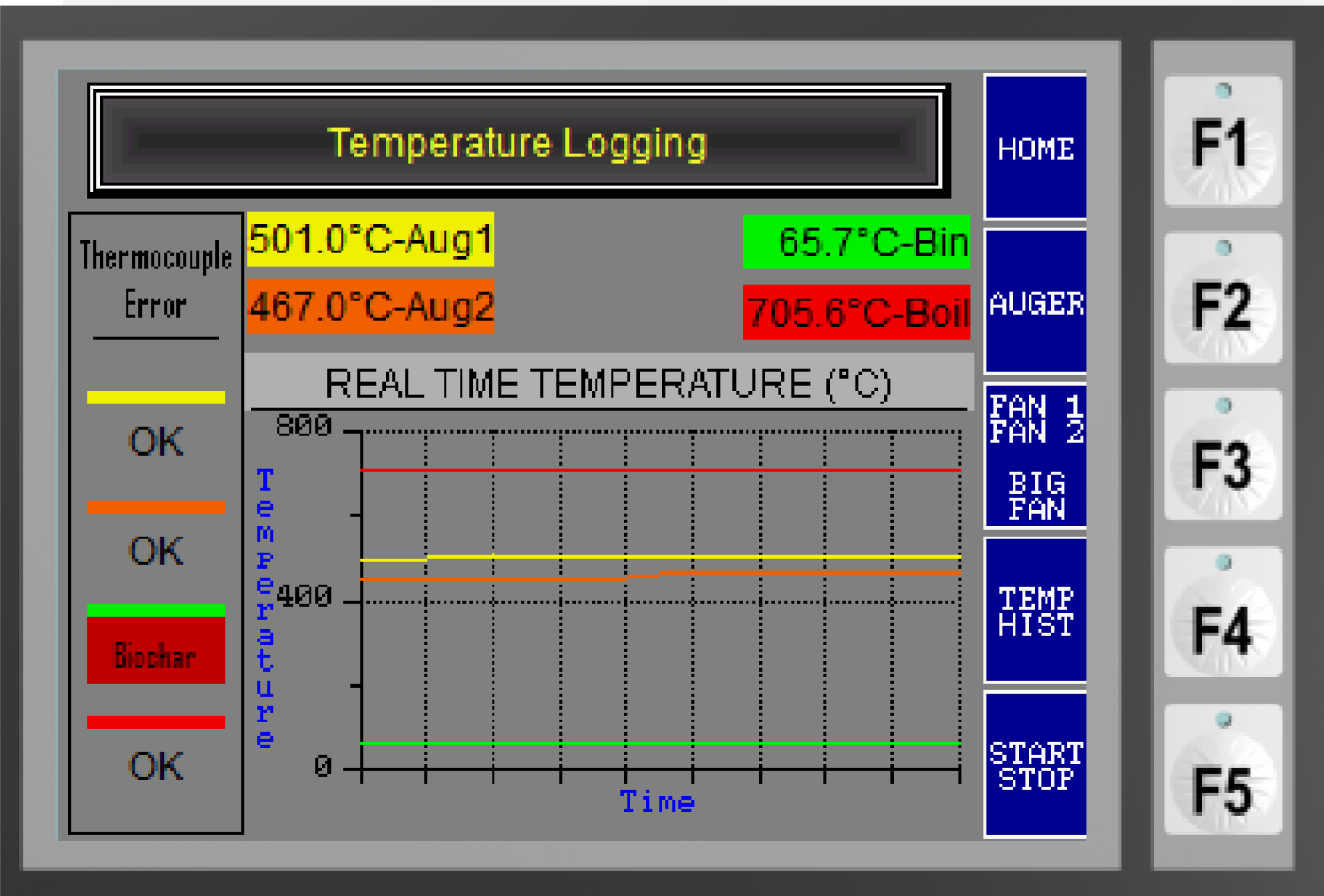
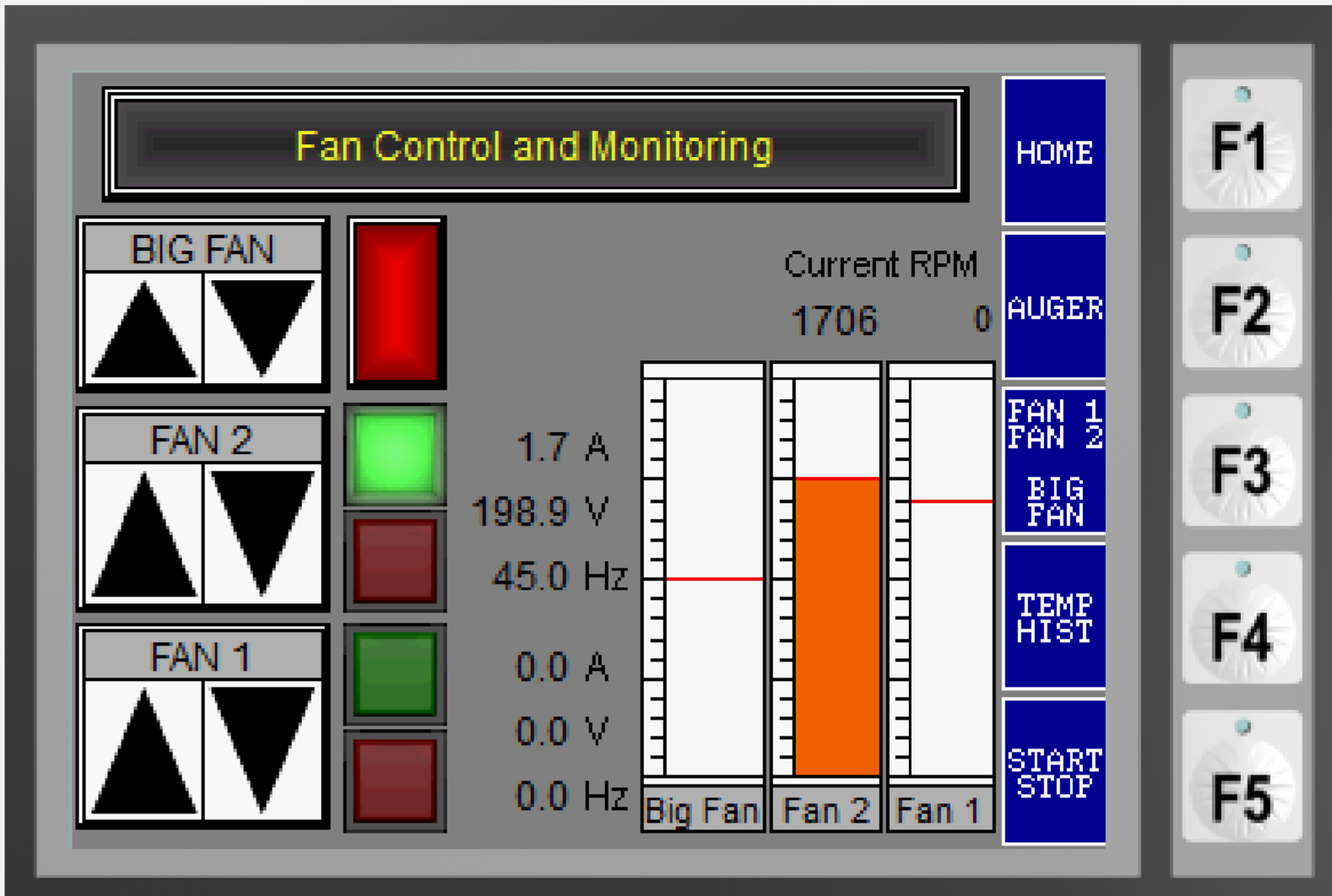
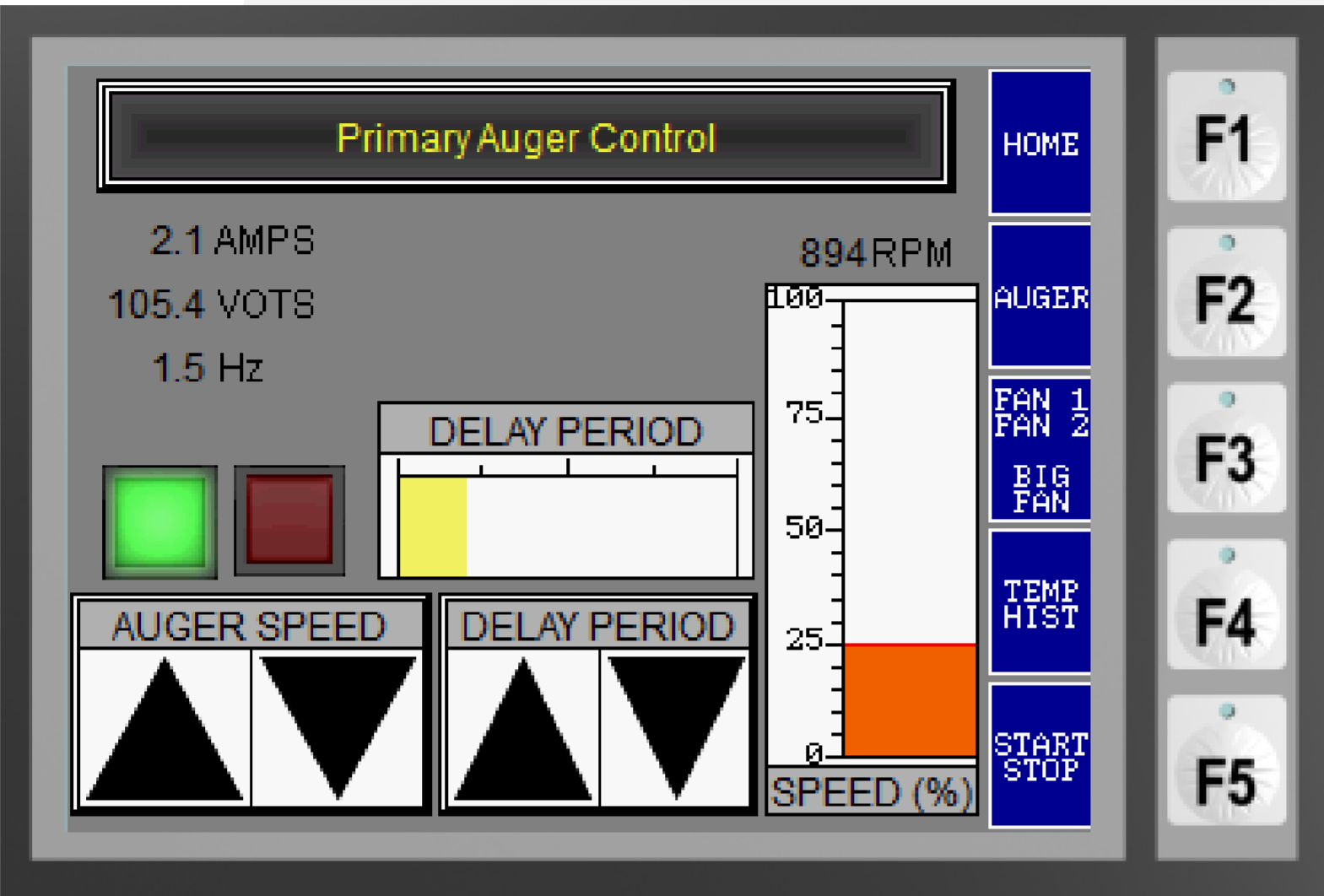



PROJECT MANAGEMENT



FINAL PROTOTYPE

FINAL PROTOTYPE



FINAL PROTOTYPE

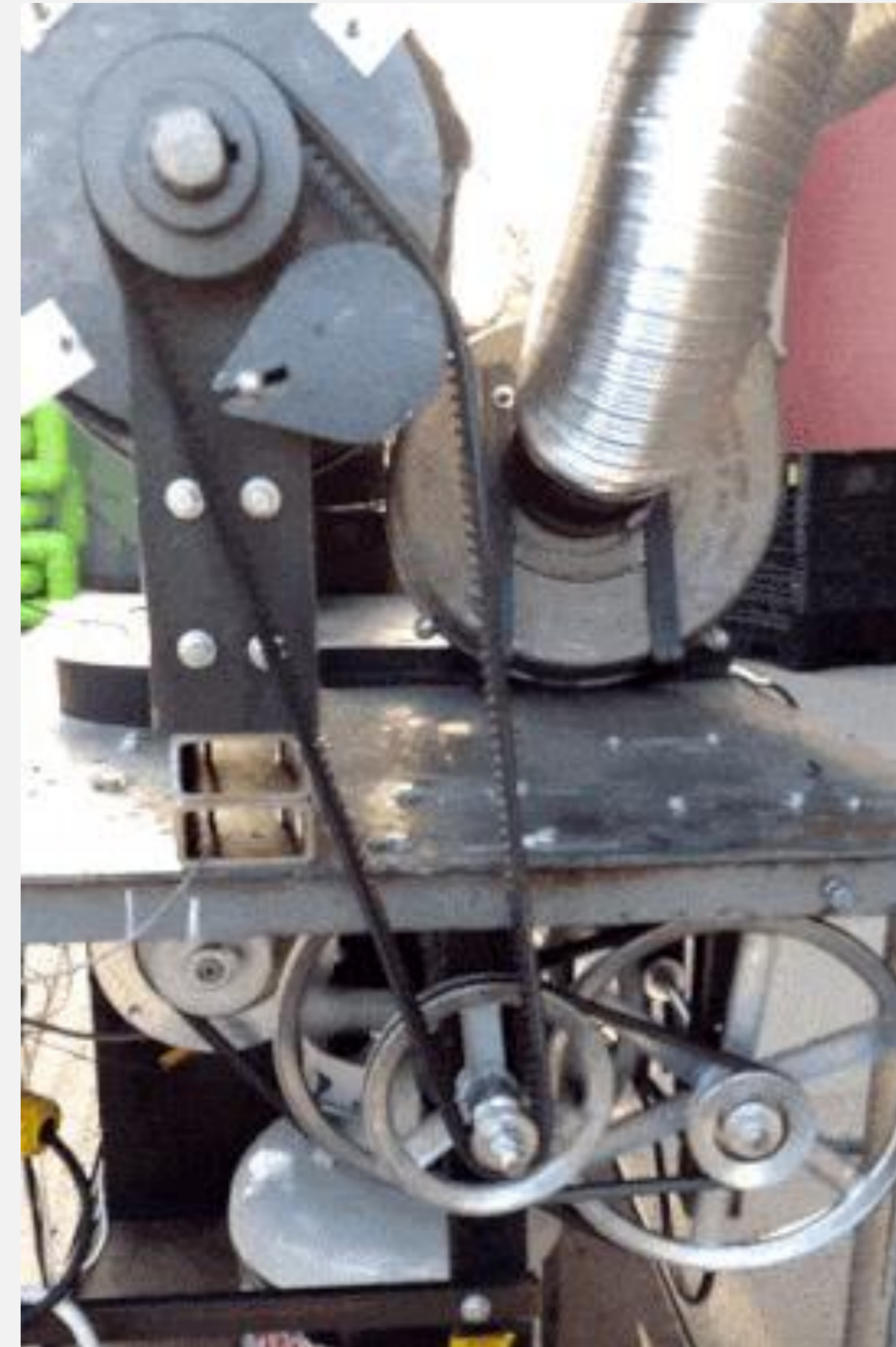
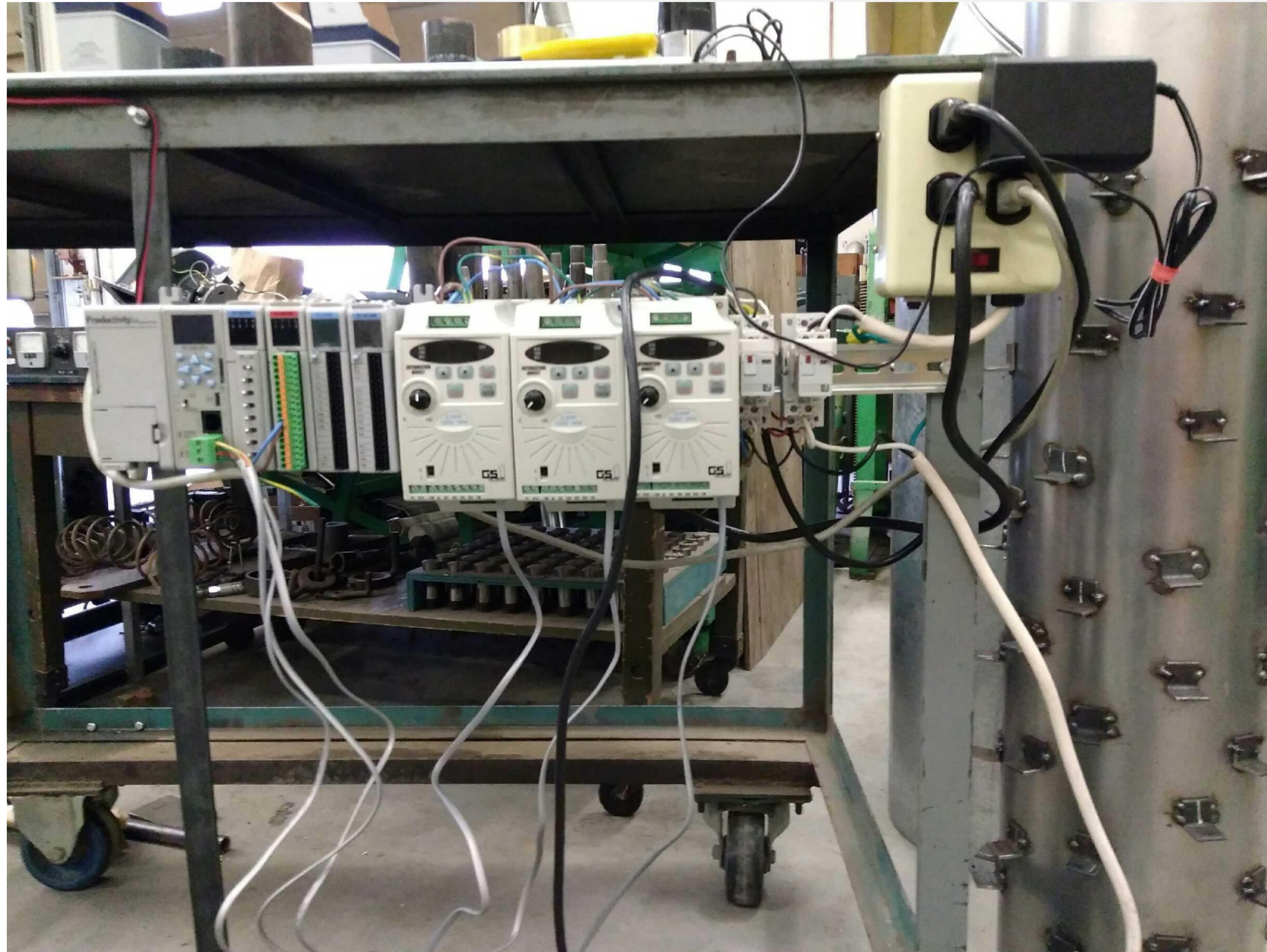

QUESTIONS?

