

Smooth Sanding Device For Arthroscopic Surgeries

Jett Murray, Maclean Landis, Lucas Dibelius, and Ryan Crowell

Objective

The objective of this project to complete development of a previously constructed arthroscopic bone and cartilage shaver for the following:

- Allow for appropriate sanding of bone and cartilage surfaces via approximation of a random orbital sanding motion
- To strengthen the device and provide a robust tool for manufacturing and testing

Background

- Osteoarthritis (OA) is a characteristic roughening of the joint, causing frictional pain that can be chronic
- ~750k knee arthroscopies occur annually in US for OA pain mitigation, and often require excision of damaged tissue
- Commonly used arthroscopic shaver heads often leave grooves in the areas that have been shaved as a result of tissue resection. This further irritates joint tissues and leads to a longer rehabilitation periods

Value Proposition

- Currently, no technology exists to re-shape damaged joint surfaces, which could lower patient rehabilitation times
- This device aims to create a random-orbital sanding platform for OA arthroscopic surgeries to improve patient outcomes
 - Allow reshaping of bone and cartilage to treat OA pain via smoothing cratered surfaces
 - Incorporate inexpensive, reusable tooltips to reduce patient costs

Key Requirements

- Variable output speed from 900-6000 RPM
- Random orbital sanding
- Hypoallergenic, replaceable tooltips
- Output shaft- 5mm diameter
- Modular tooltips, different grits
- Reliable 2-hour intermittent battery life with modular power supply
- Reusable device with reusable tooltips capable of sterilization

Concept Development and Theoretical Modeling

- Two initial designs: Sawzall DC motor and linear actuator, fixed DC motor with linear solenoids
- Reliability concerns directed to second option
- Preliminary testing with first prototype yielded approved results
- Completed circuit and coding
- Inner mechanism machined
- 3D Printed most remaining parts
- Awaiting MarkForged Printer for final handle

Final Design and Manufacturing

- Design functions with DC motor mounted linearly to the rotating shaft, conjunctive to 4 micro solenoids working in tandem to create linear actuation
- Achieves linear and rotational motion
- Potentiometer controls revolutions, toggle to activate
- Cylindrical rounded shaving head
- Final Prototype
 - MarkForged Printer for final handle

Validation

- Testing different tooltips against cow and pig thigh bones from Vandal Meats

CAD Modeling

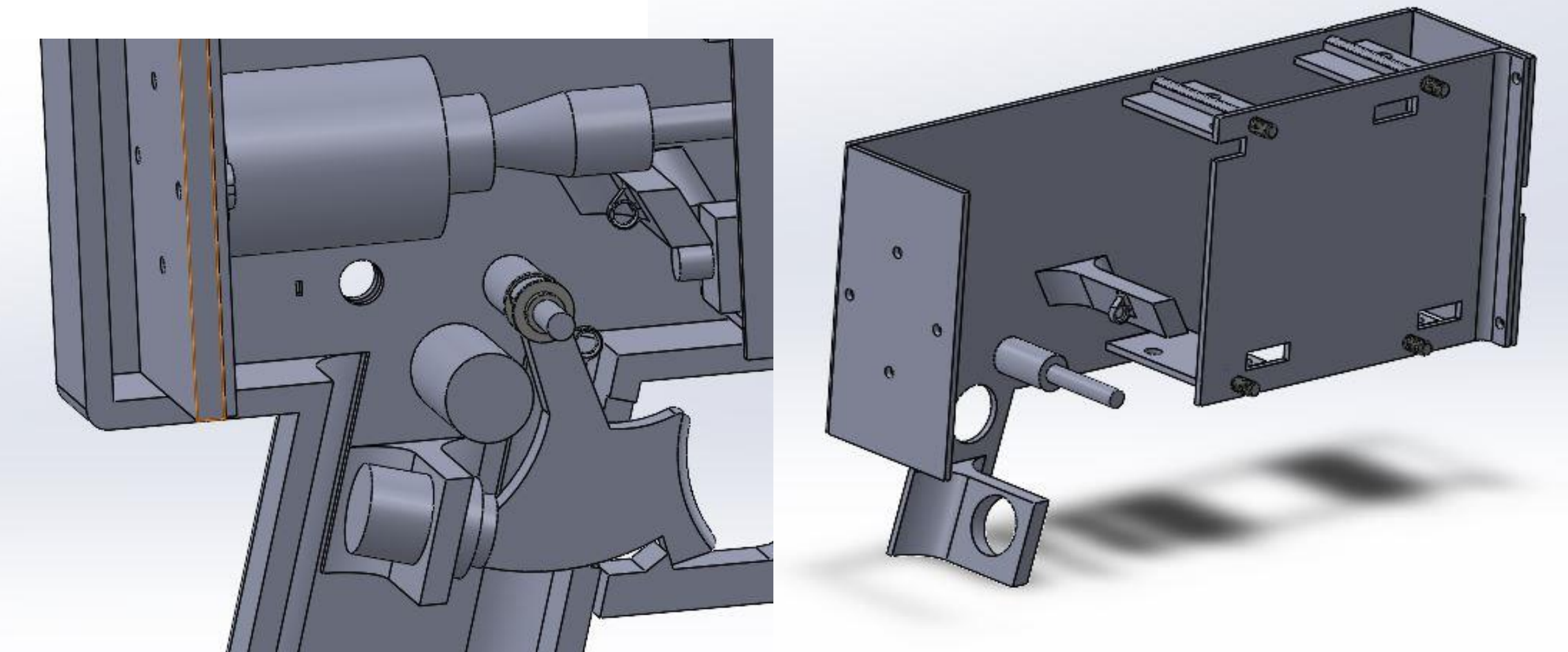

- As you can see the parts withing the handle are close together yet have a little wiggle room
- Added a wall for the other side of the solenoids to prevent any unwanted rotation from the solenoid platforms

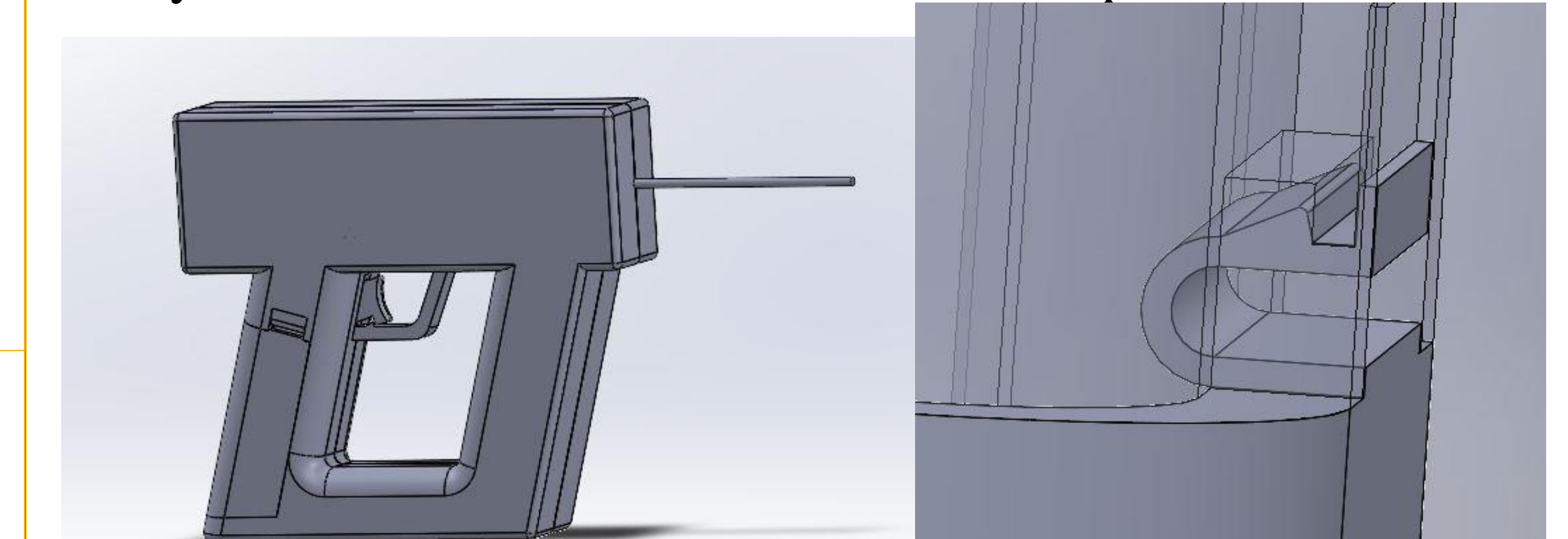

Project Management

- \$800 spent with \$700 remaining
- Large percentage going towards 3D printing

With 3D printing nearing completion next steps will be:

- Check to see if any components need to be repositioned
- Testing shaver in porcine and bovine models
- Ensure that no unwanted grooves are left behind
- Compare performance of shaver with current technology on the market
- Performing final tests to ensure shaft stays perfectly steady in use

Acknowledgements

The team would like to thank the client, Dr. Doug Hiller, for his support and contribution to the project.

Oscillating Spiral 1/pi Ratio After 36 Rotations

