



Team Sound Assist

Adam Seubert, Alex Inskeep

Client: Dr. James Frenzel
Mentor: Dr. Feng Li





Problem Statement

- Speech in noisy media can be difficult for the hearing impaired
- Action sounds can make it difficult to understand characters





Project goals

- To create an assistive listening device to increase the intelligibility of human speech in common media, such as movies and television
- The device *must* increase the intelligibility of human speech
- The device must easily integrate with a home theater system



Design Overview

Analog Audio Stream



Sound Assist Device

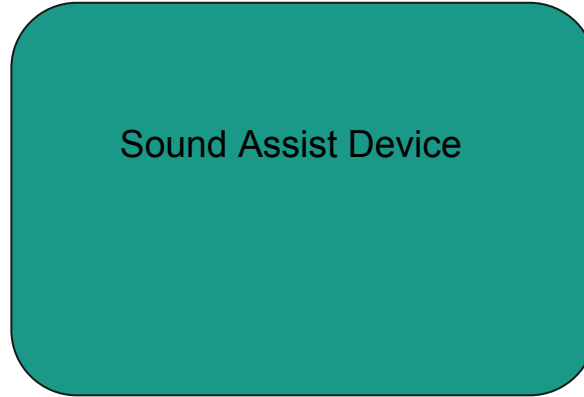

Vocal Boosted Analog Audio Stream





Technical Approach

DUET

- Blind Source Separation Algorithm
- Isolate and amplify the human voice

Filtering

- Separately Increase the volume of the human voice frequency range
- Remix with scalar values to achieve greater intelligibility

Hardware Design Overview

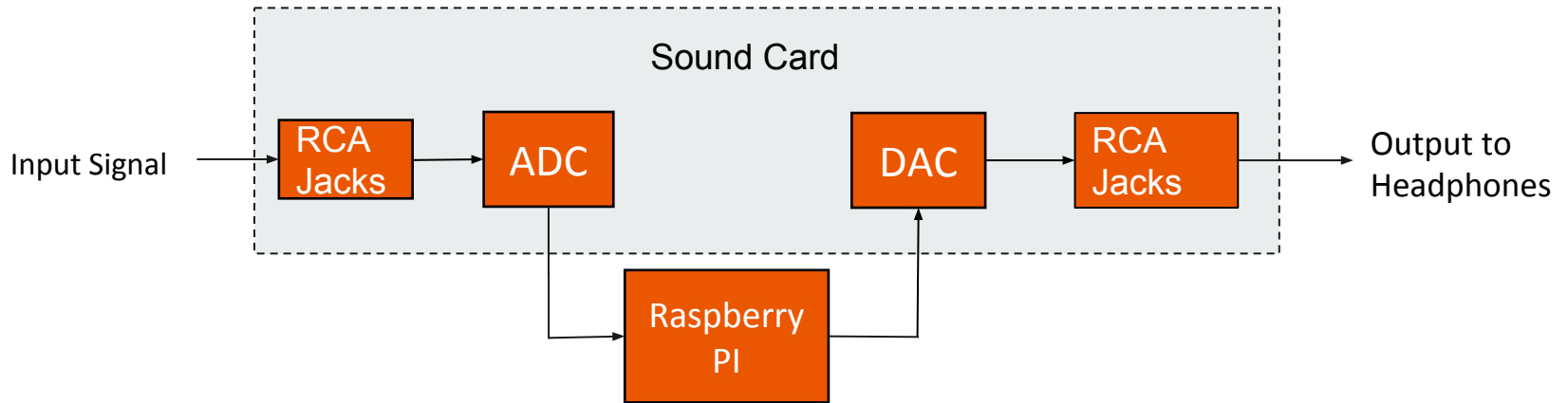

Device Overview

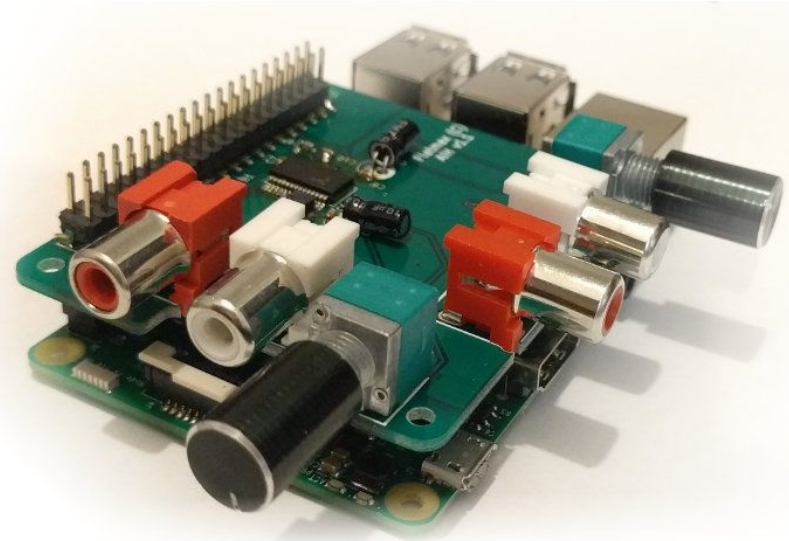
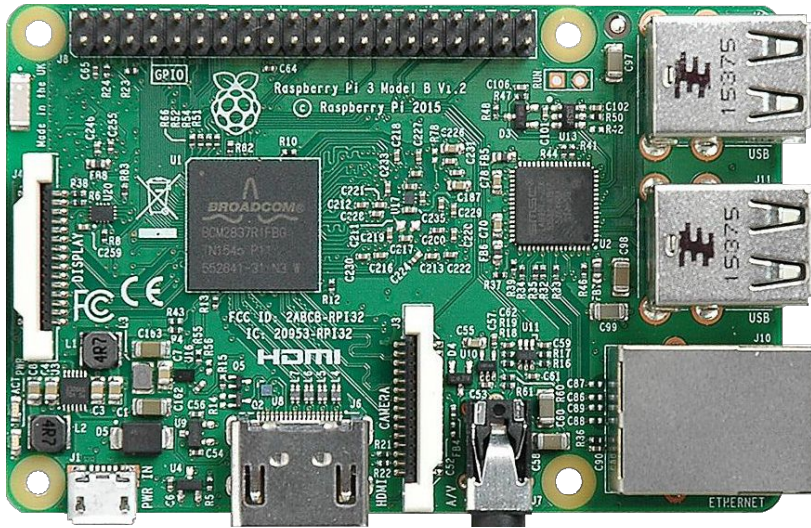

Use Case

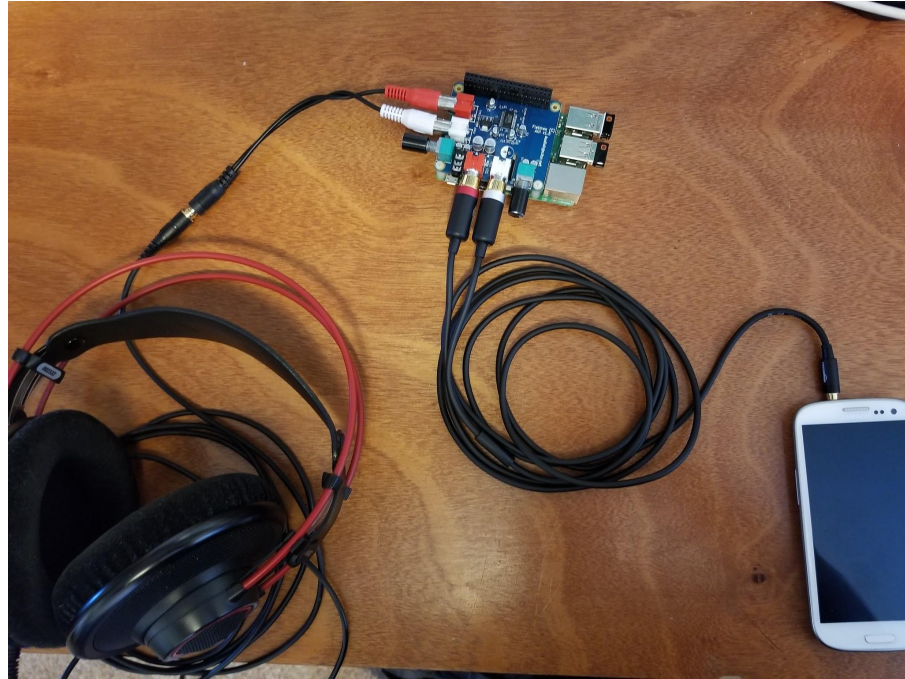

Software Design Overview

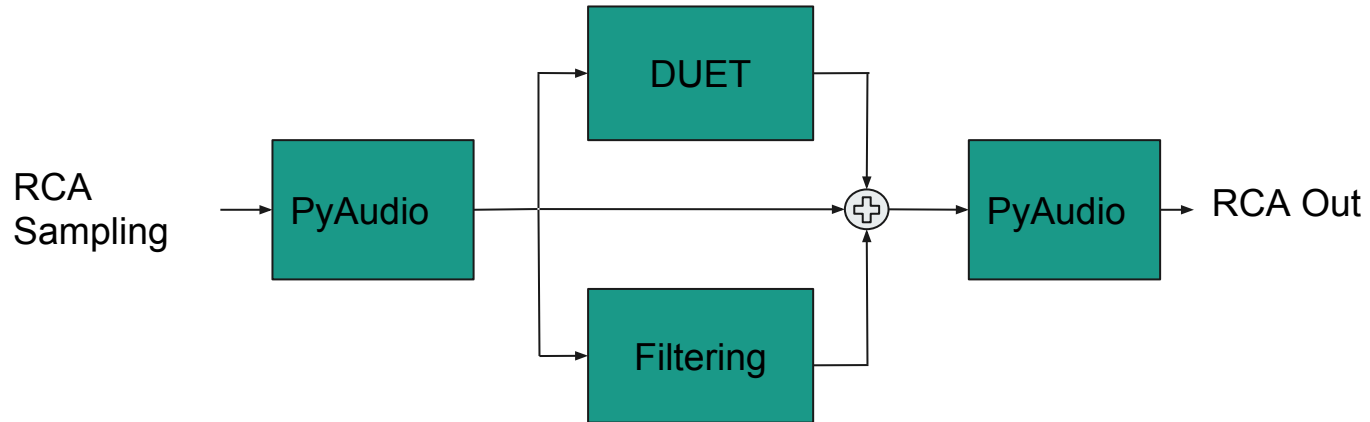



PyAudio

- Python package to help facilitate audio recording and playing
- Using a callback method to reduce sound lag
- Samples small amount of audio, processes, and plays back

Filtering

- Apply a 3rd order bandpass filter to a copy of the original sample
- Cut off frequencies are 1kHz and 5kHz
- Mix filtered signal and original with linear scalars to increase vocal intelligibility

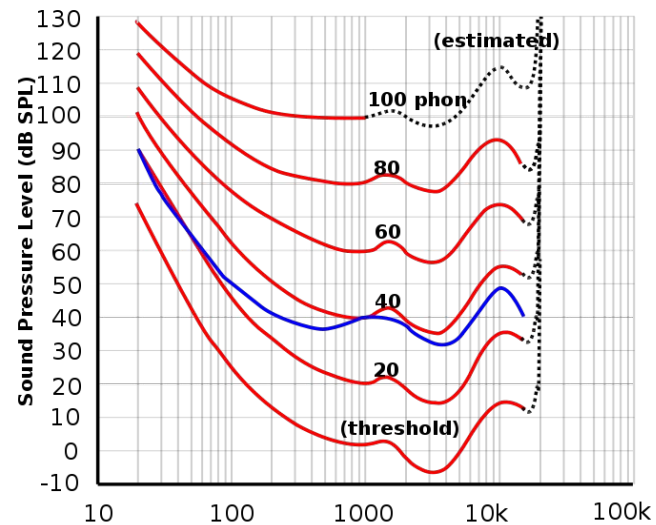

Duet

- Using only 2 inputs, it can separate an arbitrary number of sources so long as the phase-frequency representations of each source do not overlap
- Creates a 3D weighted histogram of the phase-frequency data and the peaks of the histogram are the separable sources

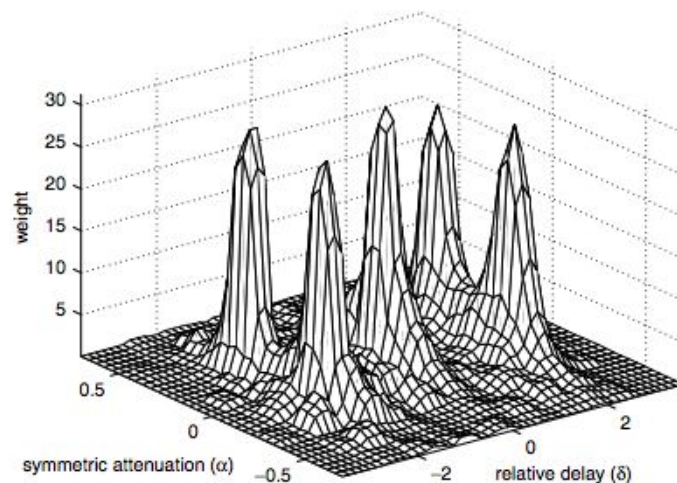



Demo

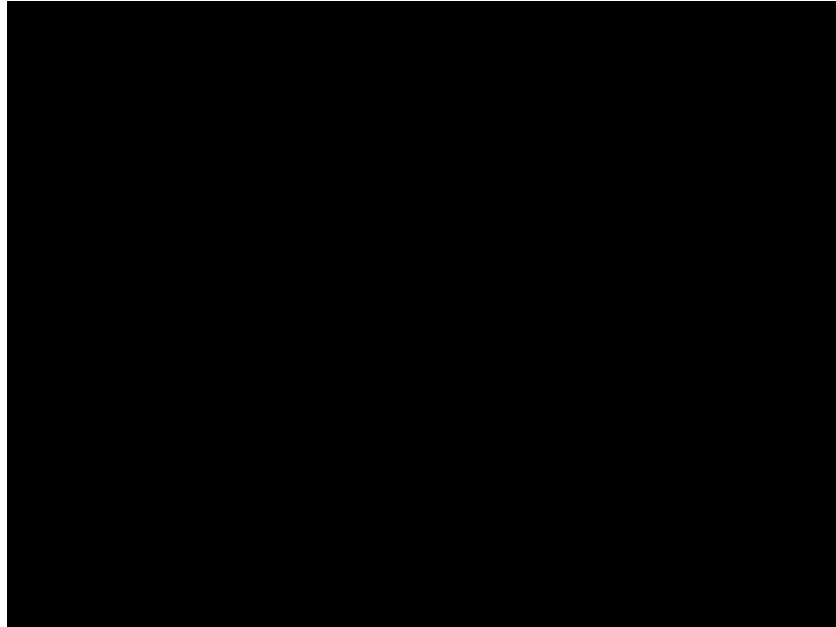



End Product

- Plug and Play experience
 - Scripts start all programs on powerup
 - No additional connections or UI needed
- Compact and powerful solution with future options



Future Work options

- Portability
- Wireless (Bluetooth, wifi)
- Real time DUET
- Customizable user profile
- User controlled knob for isolated vocal gain



Got Questions?