

Team: James Bradley, Jared Gray, Logan Matti, and Matthew Uptmor

### Problem Statement:

A glove box is required to protect people from the potentially harmful conditions that could arise from the testing of certain alloy such as INL's current project using U-Pu-Zr alloys. Most High Strength Tensile Testing Systems with heaters are too large to fit into a glovebox needed for the alloys.

### Value Proposition

The goal is to create an easy to assembled small-scale tensile testing system for an existing glovebox, fitting through an 8-inch hole and be easily assembled once inside.

### Key Requirements

- Must be able to complete a tensile test and gather data
- Must be able to run a test at 700°C.
- Must fit through an 8-inch glove hole
- Must be easy to assemble with gloves on

### PID Instrumentation Design:

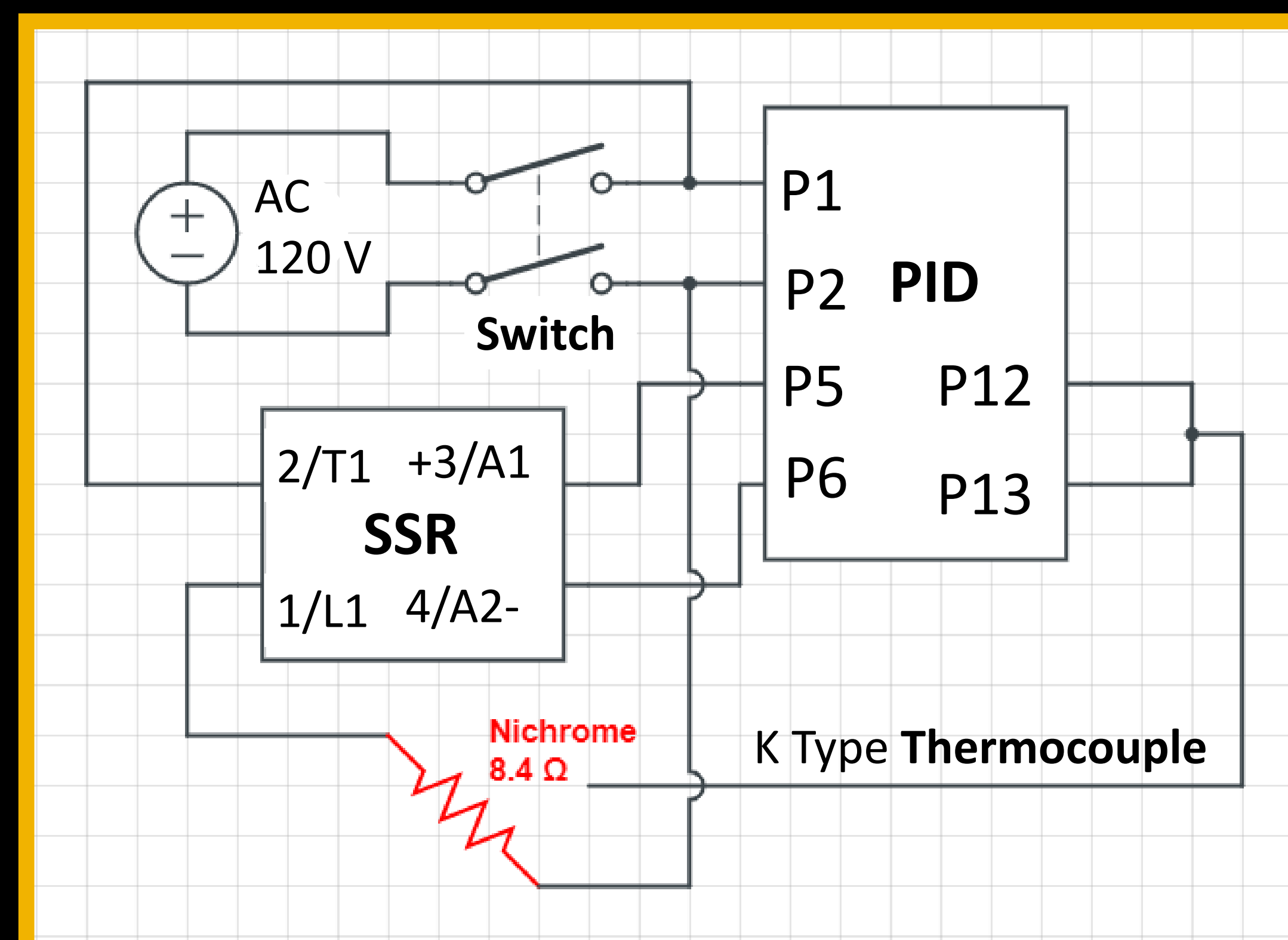

- **Power Supply:** AC 120 V
- **Emergency Stop Switch:** User shuts off entire system in case of PID run off.
- **PID:** Proportional Integral Derivative Controller – User interface to control and monitor nichrome wire temperature.
- **SSR:** Solid State Relay – on or off switch supplying external voltage to nichrome wire.

### System Design:



### Frame:

- **Top Plate:** Holds the linear actuator as well as supporting guide rods.
  - **Linear Actuator:** Providing a maximum 1500 [lbf] with a safe operating limit.
  - **Guide Rods:** Creates the path for the linear actuator to provide tension.
  - **Cross Head:** Connects linear actuator to grips.
  - **Bearings:** reduces the friction between the cross head and guide rods.
  - **Grips:** Supports specimen connect to cross guard and load cell.
  - **Load Cell:** Measures the force on specimen.
  - **Base Plate:** Supports entire frame.
- ### Heater:
- **Shell:** Retains heat from heater and provides safety to user.
  - **Refractory Bricks:** Main insulator to heat specimen.
  - **Support Legs:** Supports static heater shell.
  - **Nichrome Wire:** Heats the specimen and heater air to a max of 800°C.

### User Interface:

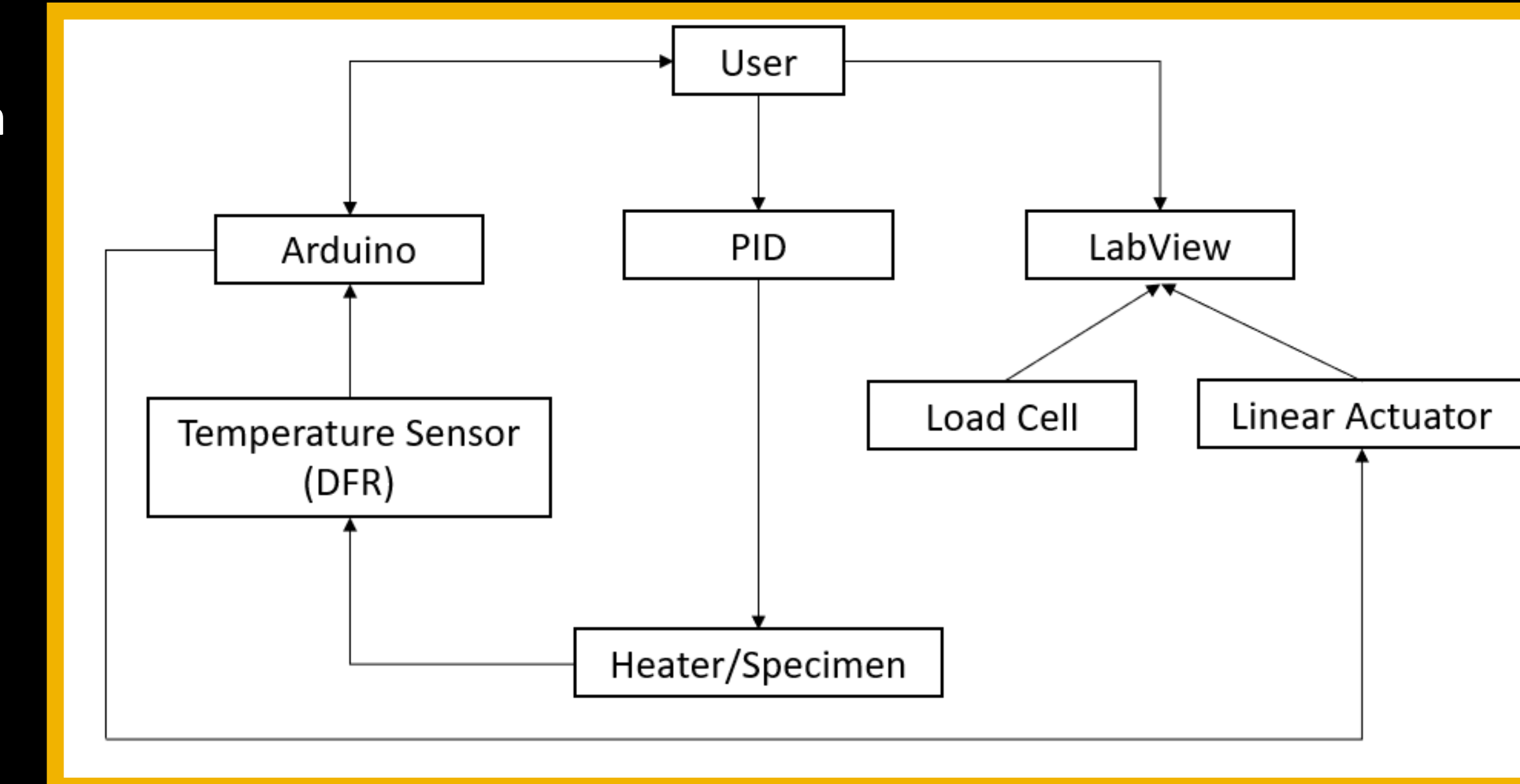

- This diagram shows how the user will interface with the instrumentation which is housed by a control box and connected to the system and a computer.

### Base Plate Stress Analysis:

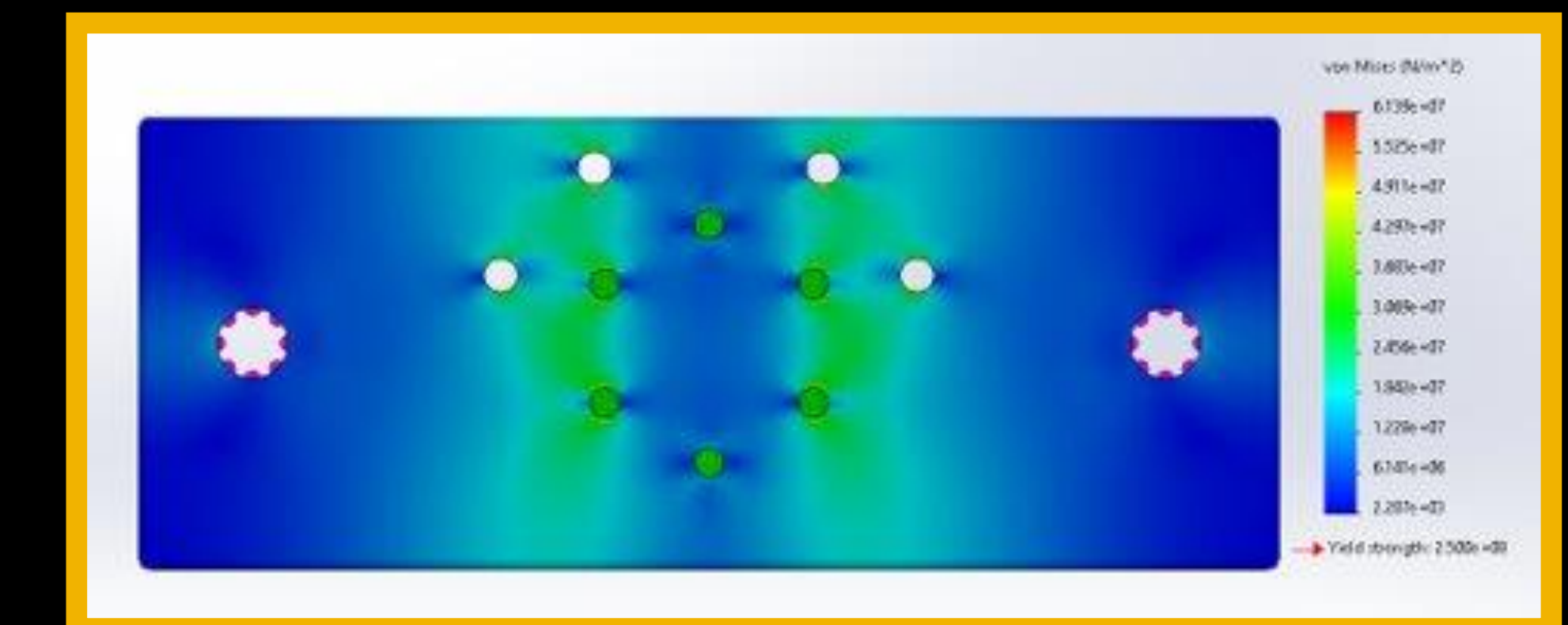

### Load Cell Validation Values:

Weight (lbf)	Reading (mV)	Load Measured
0	0.41107	0
10	0.4264	10.0002
20	0.436621	20.0004
30	0.446841	30.0006
40	0.467062	40.0008
50	0.467282	50.0011
60	0.477503	60.0013

### Load Cell Validation Graph:

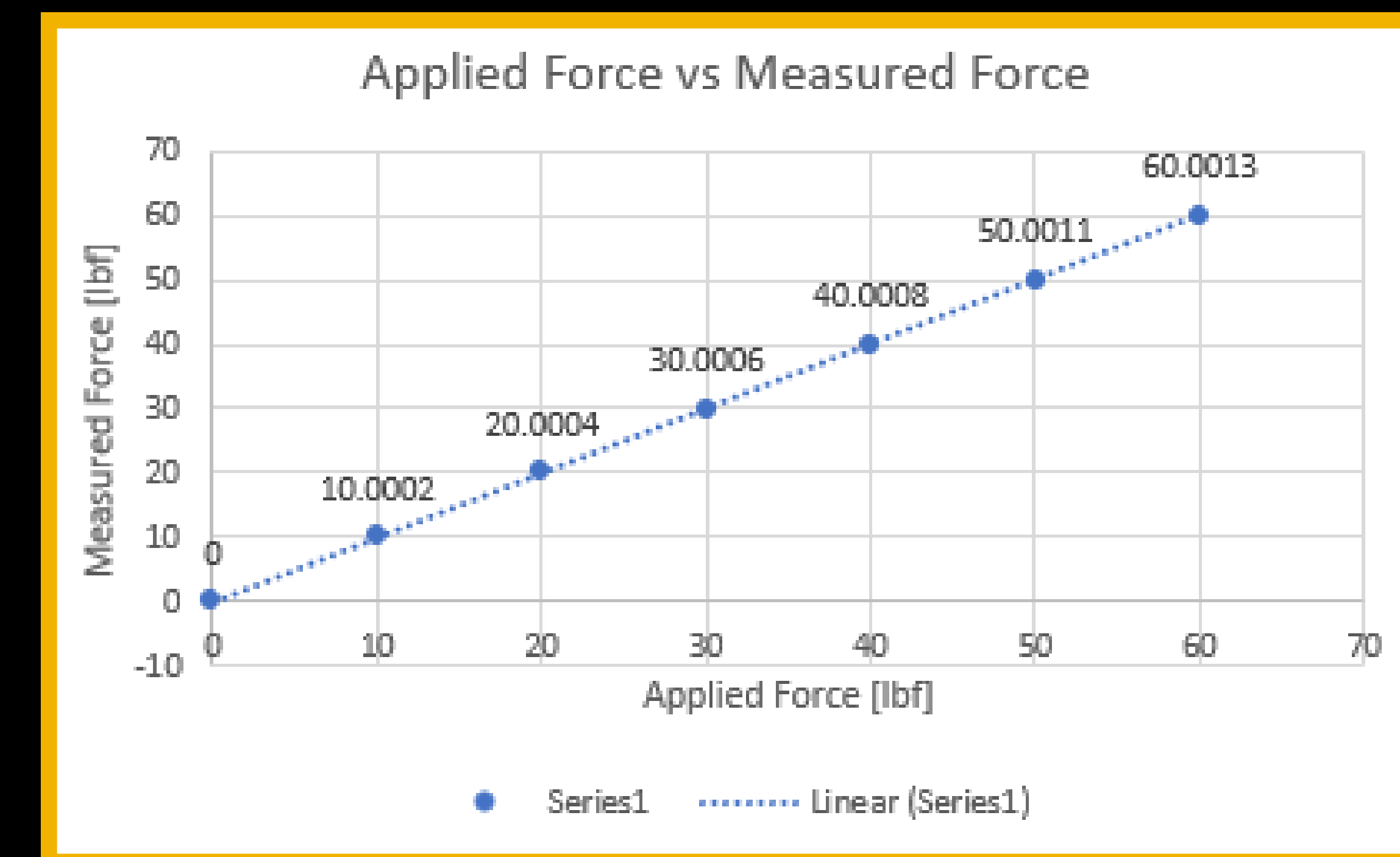

### Manufactured Frame:



### Acknowledgements

We would like to thank Randall Fielding for Idaho National Laboratory for funding and assisting our project, our lead instructor Dr. Michael Maughan, our mentor Anas Nawafleh, and the ME shop manager Bill Magnie.