



RANGE & ANGLE TRACKING

Range Tracking
Angle Tracking
Tracking Moving Targets



What is Range Tracking?

- It is an extension to the independent measurement of range on a pulse by pulse basis
- It involves using the previous estimate of the target range and information about its velocity to predict where the target will be in time for the next range measurement
- This prediction is then used to constrain the area observed when detecting the next echo
- Most range tracking systems use a type 2 (2 cascaded integrators) to predict the position of constant range-rate targets with zero lag

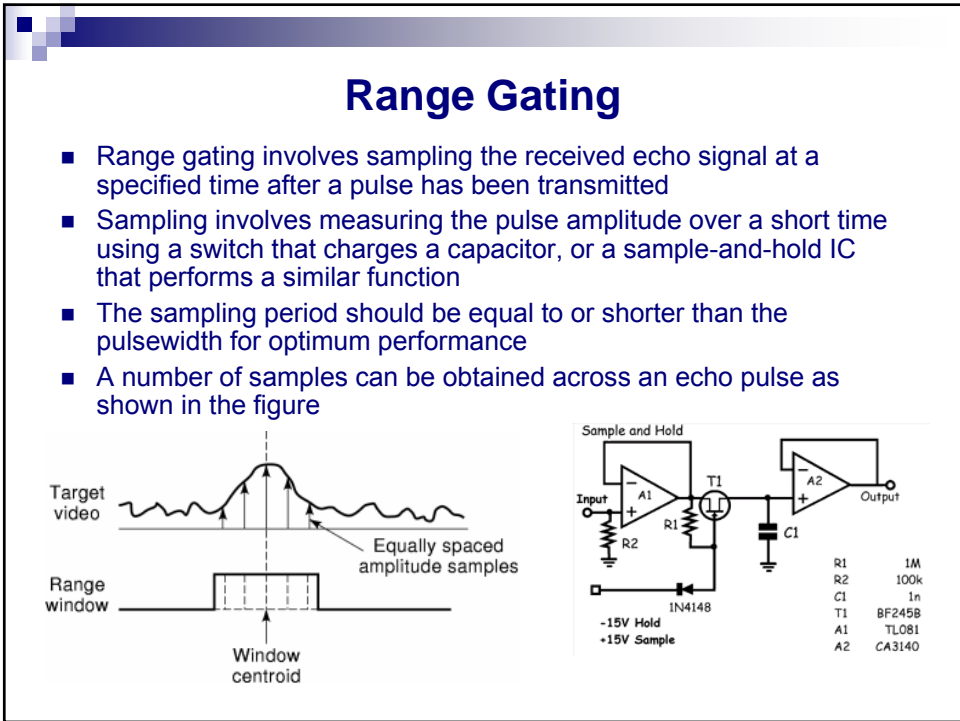
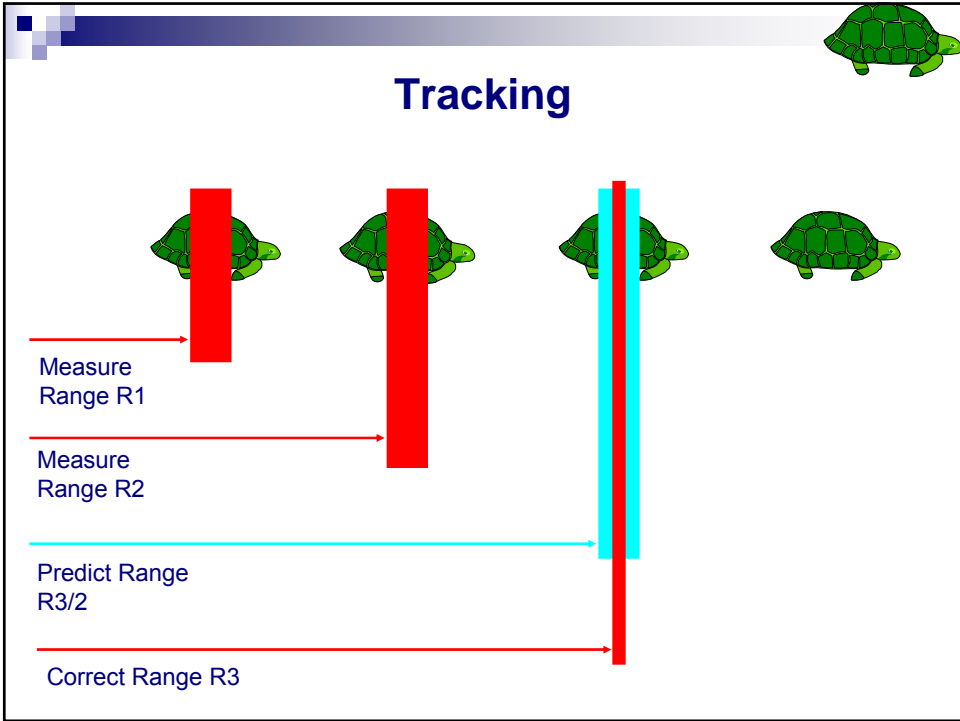

The Split Gate Tracker

- Consists of two sample-and-hold circuits triggered about one half of the pulse width apart. These are called the early and late gates
- The output of the S&H is the integral of the voltage in the echo pulse within each gate
- The difference between these voltages is equal to the range tracking error, and it is used to drive the tracking filter which in turn moves the gate timing to centre the gates ready for the next echo pulse

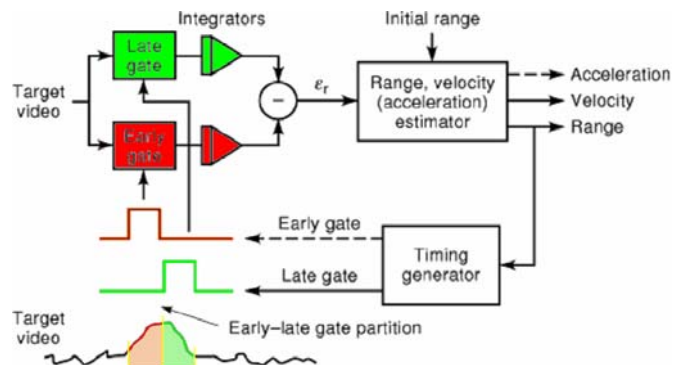

Tracking Error Transfer Function

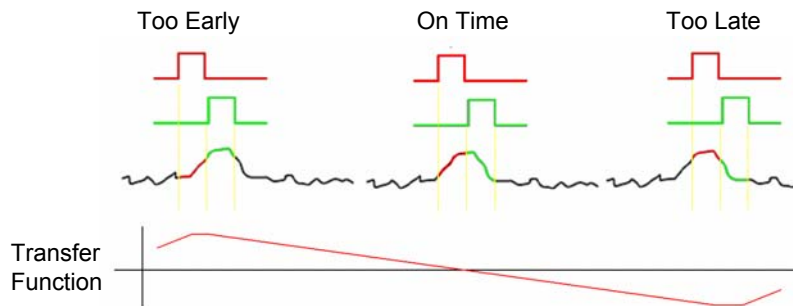

- If the split gates are early with respect to the echo pulse, then a positive error is generated
- If they are aligned, then the error is zero
- If they are late, then the error is negative
- A continuous transfer function can be determined that maps the timing error into a voltage error

Measuring the Transfer Function

Echo Pulse Moving Through Gate

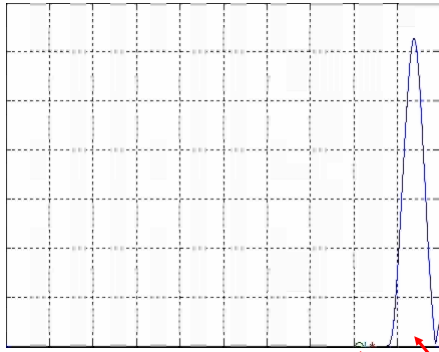

Split Gate
Sampler

Echo Pulse

Measured Transfer Function

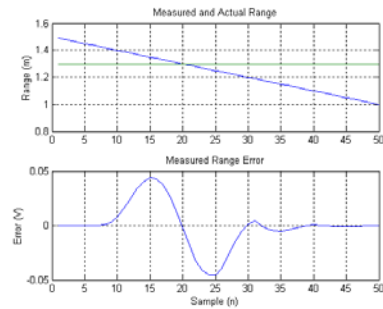

Tracking Noise

- For a matched system, the range noise variance on the output of a split gate tracker for $1 < \beta\tau < 2$ and $\tau < \tau_g < 2\tau$ can be determined as follows

$$\sigma_r = \frac{\tau}{2.5\sqrt{2S/N}}$$

Where τ - pulse width (m)
 τ_g - gate width (m)
 S/N - signal to noise ratio

Analog Tracking

- For constant loop bandwidth, the error signal $V_L - V_E$ must be normalised otherwise the error will be a function of both the target RCS and the range
- Normalisation is achieved using an automatic gain control (AGC) loop that maintains a constant echo target echo amplitude
- The normalised range error drives a 2nd order tracker implemented by a pair of cascaded integrators

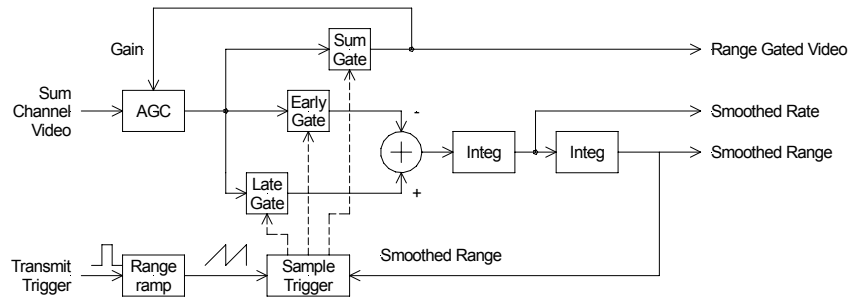

Digital Tracking

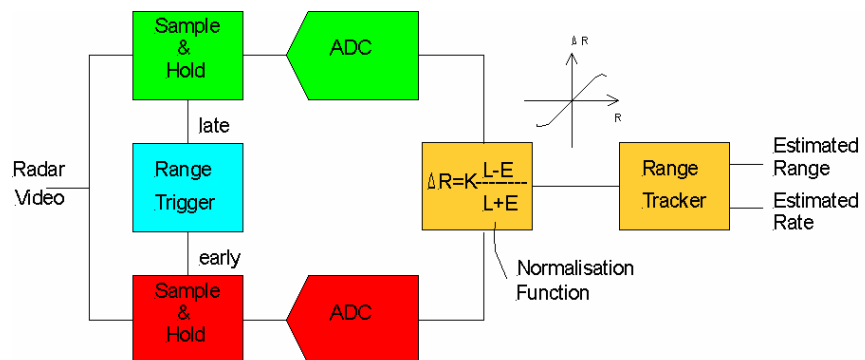

Digital Filtering

- The primary object of tracking filters is to minimise the output noise variance under specific input conditions (usually constant velocity target motion)
- Kalman filters and α - β trackers are widely used for track-while-scan and single target tracking applications
- The α - β tracker is a fixed gain formulation of the Kalman filter and is still widely used because it is easy to implement and performs well
- It has the standard smoothing – prediction structure which is typical for tracking filters

α - β Filter Implementation

- Smoothing

$$\hat{R}_n = \hat{R}_{pn} + \alpha(R_n - \hat{R}_{pn})$$

$$\hat{V}_n = \hat{V}_{pn} + \frac{\beta}{T_s}(R_n - \hat{R}_{pn})$$

- Prediction

$$\hat{R}_{p(n+1)} = \hat{R}_n + \hat{V}_n \cdot T_s$$

$$\hat{V}_{p(n+1)} = \hat{V}_n$$

\hat{R}_n = Smoothed Estimate of Range

\hat{V}_n = Smoothed estimate of Range Rate

R_n = Measured Range

$\hat{R}_{p(n+1)}$ = Predicted range after T_s seconds

$\hat{V}_{p(n+1)}$ = Predicted Range Rate after T_s seconds

\hat{R}_{pn} = Predicted range at the Measurement Time

\hat{V}_{pn} = Predicted Velocity at the Measurement Time

T_s = Sample Time

α, β = Smoothing Constants

Selecting Gains for the α - β Filter

- Benedict suggests that to minimise the noise variance at steady state and the transient response to a manoeuvring target modelled by a ramp function, that the coefficients will be related as follows

$$\beta = \frac{\alpha^2}{2 - \alpha}$$

- Other criteria can be used, for example, if the fastest step response time is required (critical damping), then the relationship is as follows

$$\alpha = 2\sqrt{\beta} - \beta$$

- The actual gains will depend on the sample period, the predicted target dynamics and the required tracking loop bandwidth
- One problem with the filter is that it tracks an accelerating target with a constant lag proportional to the magnitude of the acceleration
- To cater for this it is possible to either increase the order of the filter to α - β - γ , or to adapt the gains to compensate

The Kalman Filter

- The Kalman filter produces optimum filter gains (somewhat analogous to α and β) that are dynamically computed on each update cycle
- This results in an optimum filter that is matched to the noise and to the target dynamics to minimise the mean squared tracking error
- The benefits of the additional complexity include
 - Improved tracking accuracy (if the noise and target motion is modelled accurately)
 - A running measure of the tracking accuracy
 - An optimum method of handling measurements of variable accuracy, and non uniform sample rate (inc. missing samples)
 - Higher order systems are easier to accommodate

$\alpha\beta$ Range Tracker Simulation

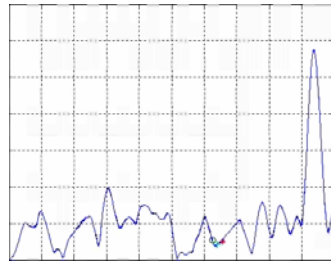

$\alpha = 0.1$

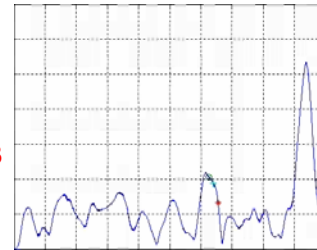

$\alpha = 0.3$

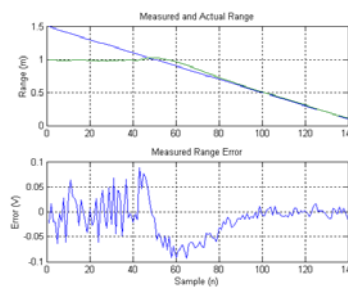
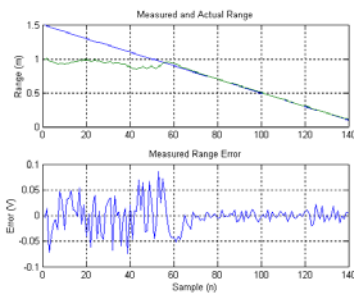

Tracking Noise After Filtering

- Measurements made over n sample periods combine in the tracking filter to provide an output whose output RMS noise is reduced by $1/\sqrt{n}$
- In terms of the equivalent noise bandwidth β_n of filter

$$n = \frac{f_r}{2\beta_n} = \frac{1}{VRR}$$

where f_r – Pulse repetition frequency (Hz)
 β_n - Bandwidth of tracking filter (Hz)
 VRR – Variance reduction ratio

- For the split gate tracker, the RMS noise output after filtering will be

$$\sigma_r = \frac{\tau}{2.5\sqrt{(S/N)(f_r/\beta_n)}}$$

Determining the Variance Reduction Ratio for a Tracking Filter

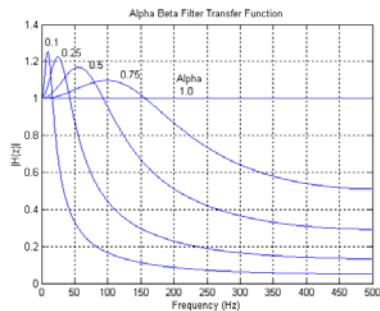

- VRR can be determined as the ratio of the power in the impulse response to the power in the impulse
- Ratio of output noise variance to input variance for white noise
- In the frequency domain it is obtained by integrating the area under the transfer function $|H(\omega)|^2$

Minimising Tracking Error

- The RMS tracking noise is determined from the input SNR and the VRR

$$\sigma_r = \frac{\tau}{2.5\sqrt{2S/N}} \sqrt{VRR}$$

- The dynamic lag is a function of the acceleration and the filter gains

$$L = \ddot{r} \frac{T_s^2}{\beta} (1 - \alpha)$$

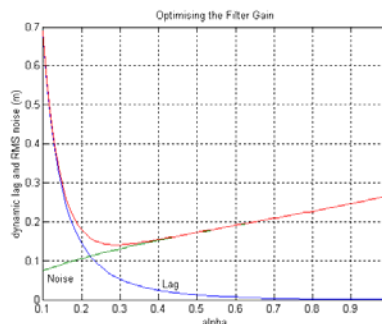

Range Tracking Systems

- Most range tracking systems are associated with angle trackers to produce a full 3D tracking capability (as shown in the video clip at the start of this lecture)
- There are a number of applications where the angular pointing function is either non-existent or performed manually
 - Combined optical and ranging systems for close in missile defence
 - Tank sights
 - Laser speed traps

Laser Speed Trap

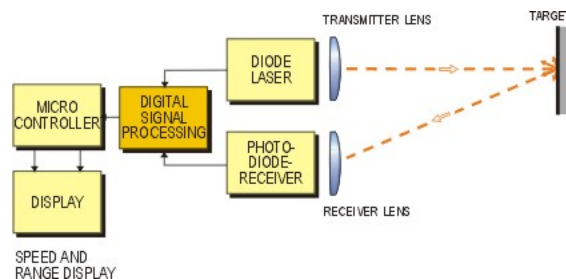

- As shown in the diagram, a standard pulsed time of flight measurement is followed by a micro-controller to estimate the target velocity
- Rate can be determined by differentiating the measured range on a pulse by pulse basis or by applying a tracking filter which produces good estimates of both range and range rate

Differentiation & Filter Comparison

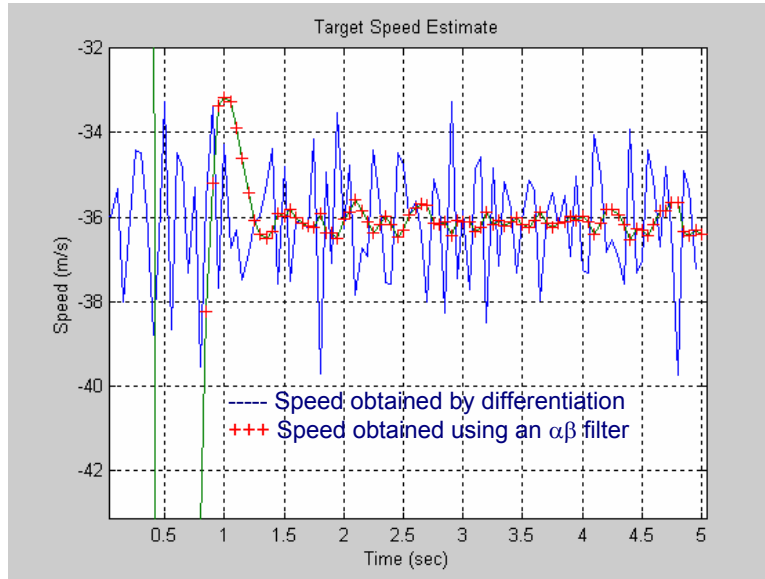

Riegl FG21-P Laser Speed Trap



958 metres away
approaching at 95km/h



937 metres away
receding at 114km/h

- Beamwidth 2.5mrad
- Measure time 0.4 to 1s
- Speed 0-250km/h
- Accuracy +/-3km/h below 100km/h
- Range 30-1000m
- Accuracy +/-10cm typical
- Target marker circular matched to beam



TRACK WHILE SCAN

Track While Scan (TWS)

- The position of an aircraft can be tracked using a conventional surveillance radar
- At its most simple, this function can be performed by a radar operator marking the face of the radar display with a pen
 - This process is inaccurate and limits the number of targets that can be tracked at one time
- Most trackers are based on automatic the following automatic process

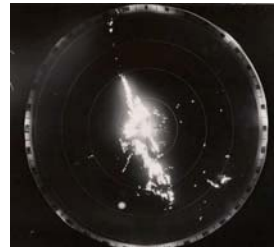

Automatic Track While Scan

- The target echo is threshold detected, but there is no velocity information, so the software constrains the measurement uncertainty to what an aircraft could achieve
- The target is detected within these uncertainty bounds, and a crude velocity estimate is determined using the target displacement. The measurement uncertainty is constrained by this measured velocity
- The target again appears within this uncertainty boundary, and a recursive tracking filter improves both the range and rate estimates by filtering. The uncertainty in the predicted position is reduced still further
- Finally, the aircraft performs a dramatic manoeuvre, and the echo does not appear within the predicted uncertainty boundary, the track is lost
- A new target is detected with no velocity information

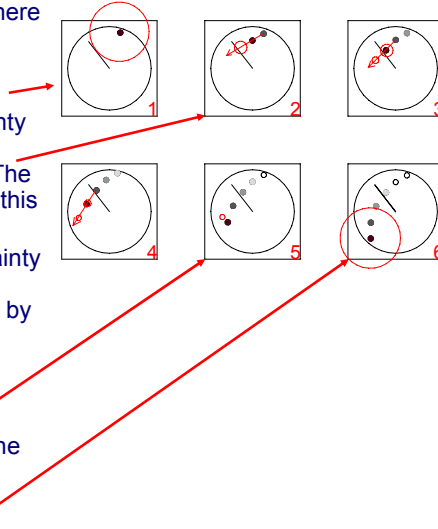

TWS Implementation

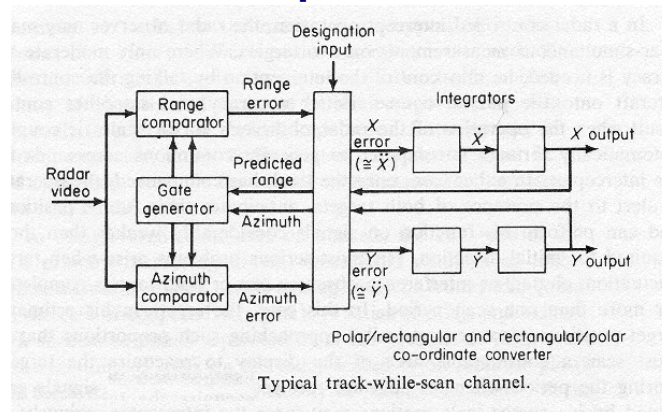

- It is possible to perform the filtering and prediction function in polar space (R, θ) , however this very non-linear in terms of the aircraft dynamics
- A more usual method is to convert the polar aircraft coordinates to their Cartesian equivalents (x, y) prior to filtering

ANGLE TRACKING

Angle Measurement

- Amplitude threshold is used to determine that a target is within the beam
- This gives a very rough measure of the target direction (within one beamwidth)
- If the echo amplitude is known then thresholding can improve the angular accuracy slightly

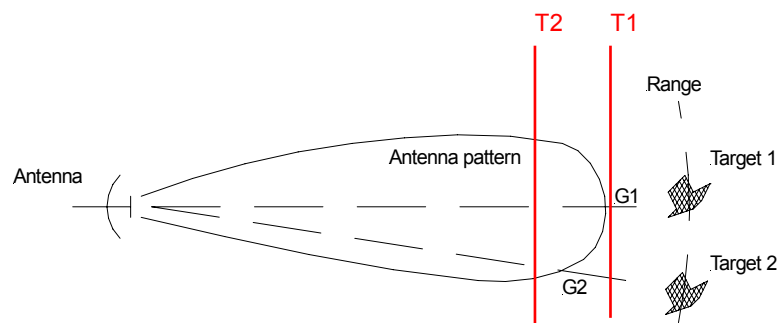

Discrimination against Interference

- Both pulsed and CW modulations can be used.
- Can be applied at microwave frequencies or in the infrared band or to acoustic signals.
- Complex modulation schemes are generally used to:
 - Discriminate against ambient solar radiation
 - Eliminate interference from fluorescent lights
 - Reduce the probability of interference from other sensors

Using Beam Pattern Amplitude

- Using the antenna beam pattern, it is possible to get a more accurate bearing on the target by sweeping the beam across it and noting changes in the signal amplitude.
- Increases the angular resolution with only a marginal effect on the range accuracy
- Reduces the “effective” beamwidth of the antenna
- Only effective if the target cross-section is constant over the sweep

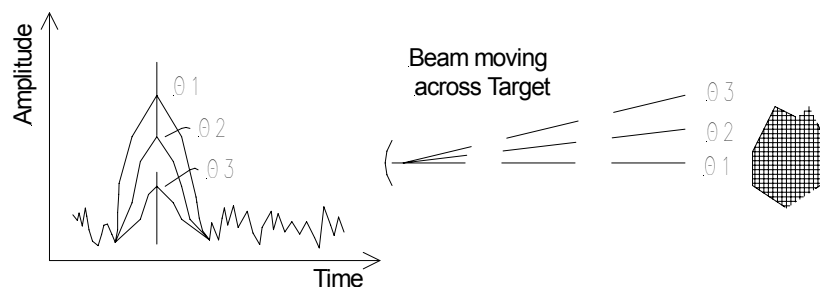

Null Steering Techniques

- Lobe Switching
- Conical Scan $k_{\text{opt}} = 1.4$
- Monopulse $1.5 < k < 2.3$

$$\sigma_t = \frac{\theta_{3dB}}{k\sqrt{2(S/N)}}$$

- Improvement in angle measurement accuracy in thermal noise is limited only by the measurement S/N

Sequential Lobing

- Sequential Transmission from two antennas with overlapping but offset beam patterns.
- Sequential returns will be amplitude modulated if the target is not on boresight.
- This AM can be used to generate an angle error estimate, or used to drive the antenna to null the error
- Two additional switching positions are needed to obtain the angular error in the orthogonal axis, so 4 pulses are required to control the antenna in 2D.

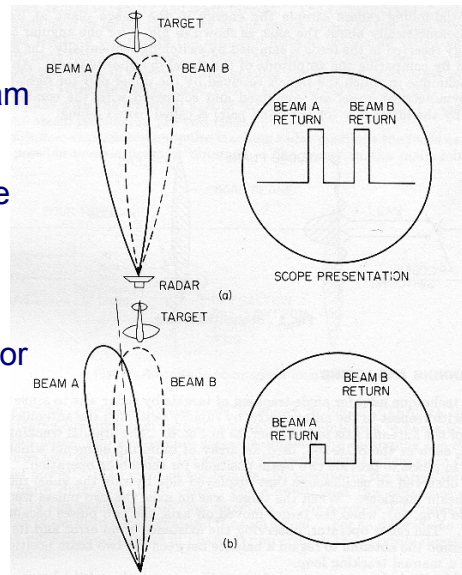

Disadvantages of Sequential Lobing

- Reduced bandwidth because 4 pulses are required to resolve the target in 2D.
- Fluctuations in the signal level due to variations in the echo strength on a pulse-by-pulse basis reduce the tracking accuracy
- Susceptible to modulation by the target, either natural (propellers, wing beats etc.) or as part of the electronic countermeasures.
- The antenna gain in the on boresight direction is less than the peak gain, so the maximum range is reduced.

Conical Scan

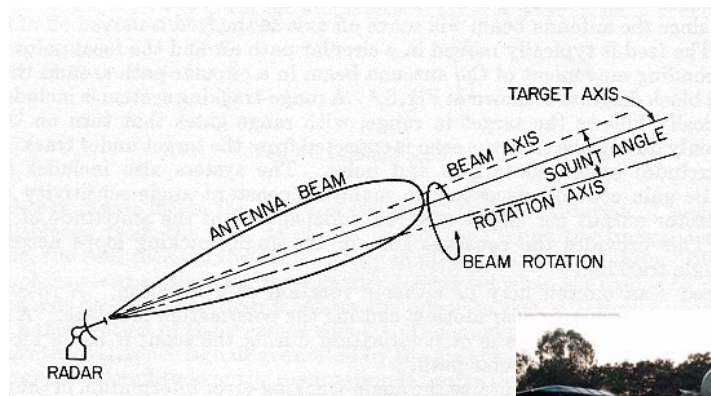

Super Fledermaus
Conscan Tracker



Technique

- A single beam displaced in angle by less than the antenna beamwidth is nutated on its axis.
- The scan rate is limited to between 5 and 25 pulses per revolution for long range operation, but can be much higher at short range
- Amplitude modulation of target returns will be a function of the position of the boresight with respect to the target.
- Phase detectors (multipliers) using quadrature phase references for the two orthogonal axes demodulate the received signal to generate the angle tracking error
- The process is similar to that used to demodulate Doppler.

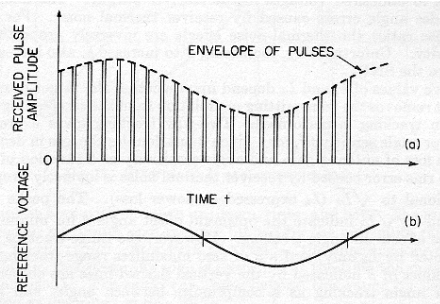

Conical Scan System

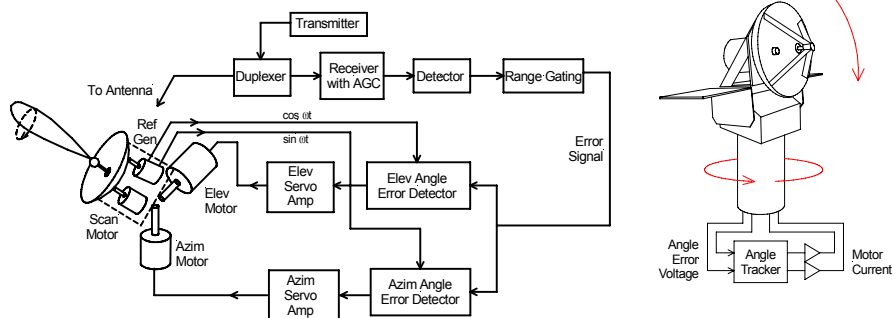

The azimuth and elevation tracking errors feed into servo amplifiers that drive the antenna to minimise the error



Demodulation Techniques

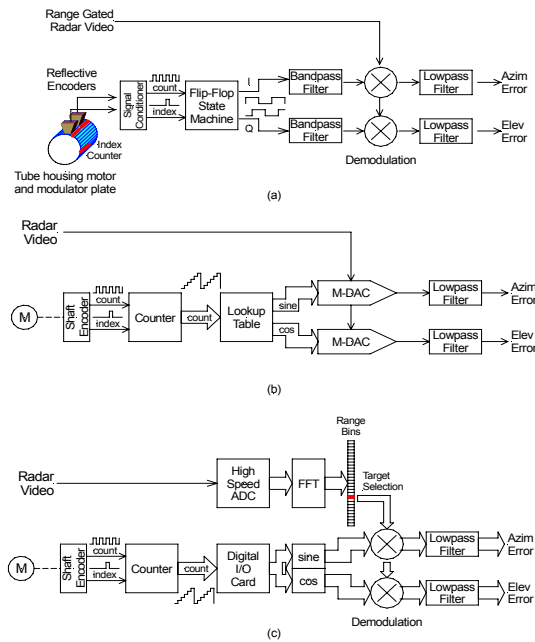

94 GHz Conical Scan Tracker

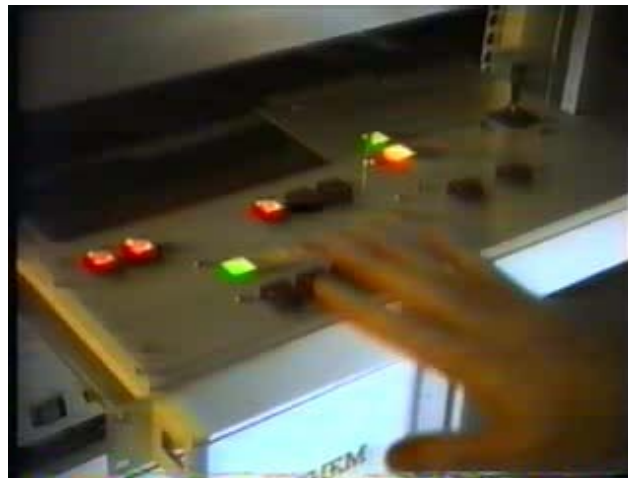

Active Conscan Tracker Boresight TV



Conscan Receiver for IFF

- Direct down-conversion 94GHz receiver
- Cassegrain antenna with a 0.6° beamwidth fitted with a conical scan sub-reflector
- Angle error demodulator



Conscan Receiver for IFF Boresight TV



Craig Lobsey's Conscan Radar



Advantages & Disadvantages

Advantages

- Simple to implement, uses a single beam and a single receiver and transmitter
- Beacon tracking can be implemented without the transmitter and without the range gating circuitry

Disadvantages

- Reduced bandwidth because of the number of pulses required for tracking.
- Fluctuations in the echo signal amplitude induce tracking errors
- Sensitive to target modulation
- Modified conscan techniques have been developed to eliminate the modulation problem:
 - Dual Conscan (Russian Design)
 - COSRO (Conscan on receive only)
- Antenna gain is reduced on boresight due to the squint angle. A trade-off is required to optimise the tracking accuracy.

Squint Angle Optimisation

- The greater the slope of the error signal, the more accurate will be the angle tracking. This occurs at θ_q/θ_B just greater than 0.4
- The gain on boresight is about 2dB down on the peak
- The range tracking accuracy is determined by S/N, and so requires the maximum on boresight gain $\theta_q/\theta_B = 0$ which is not feasible.
- A compromise is used with $\theta_q/\theta_B = 0.28$, which corresponds to an antenna gain about 1dB below the peak.

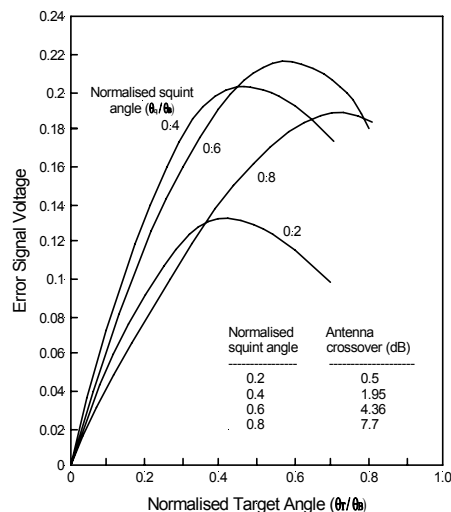

θ_q – Squint Angle
 θ_B – Beamwidth
 θ_T – Target Angle

Measuring the Conscan Transfer Function

- A conscan antenna is mounted on a pan-tilt unit and swept past a point source of radiation (in the far field of the antenna)
- The received signal level at the output of the antenna is logged as a function of time (or angle)

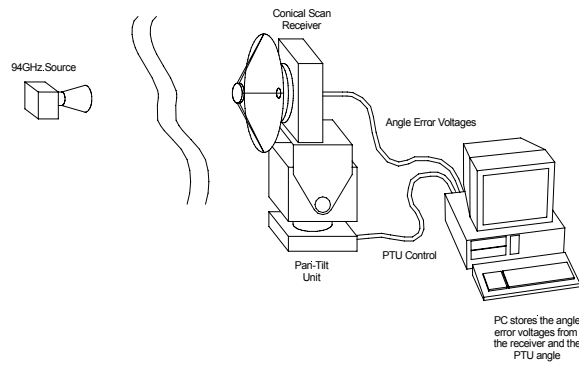

Measured Waveforms

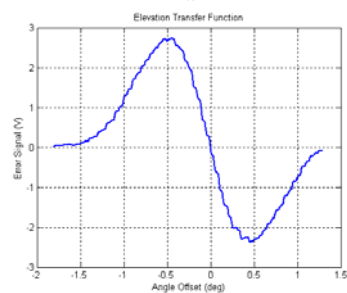
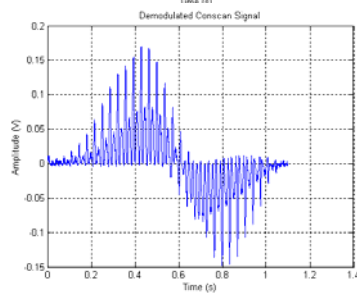
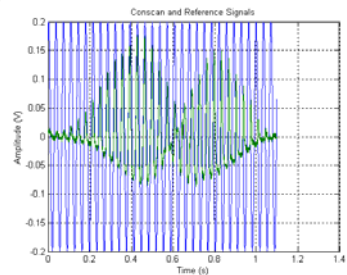
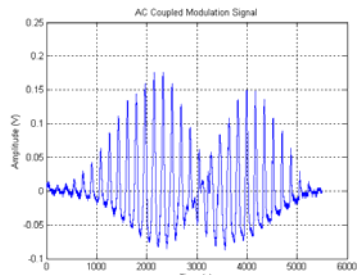

Amplitude Comparison Monopulse

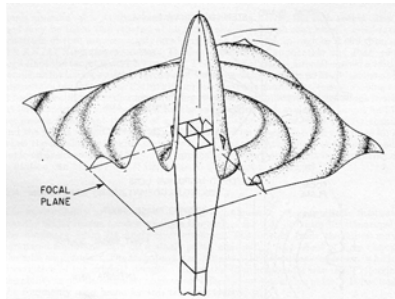

Sum Channel Signal

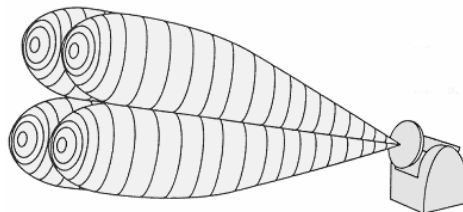

Difference Channel Signals

Monopulse Σ and Δ Signals

- Two overlapping antenna beams for each of the two orthogonal axes are generated from a single reflector illuminated by 4 adjacent feed horns
- The sum pattern, Σ , of the 4 horns is used on transmit and for range measurement on receive.
- The difference patterns, ΔAz and ΔEl , are produced on receive using a microwave hybrid circuit called a monopulse comparator

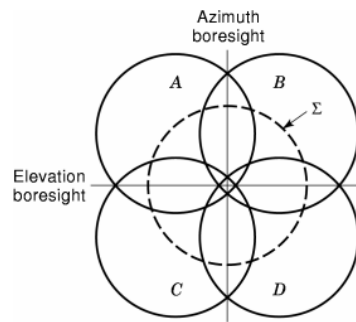

$$\begin{aligned}\Sigma &= A + B + C + D \\ \Delta_{AZ} &= (A + C) - (B + D) \\ \Delta_{EL} &= (A + B) - (C + D)\end{aligned}$$

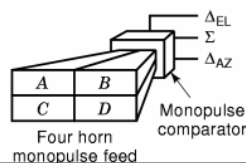

Monopulse Schematic

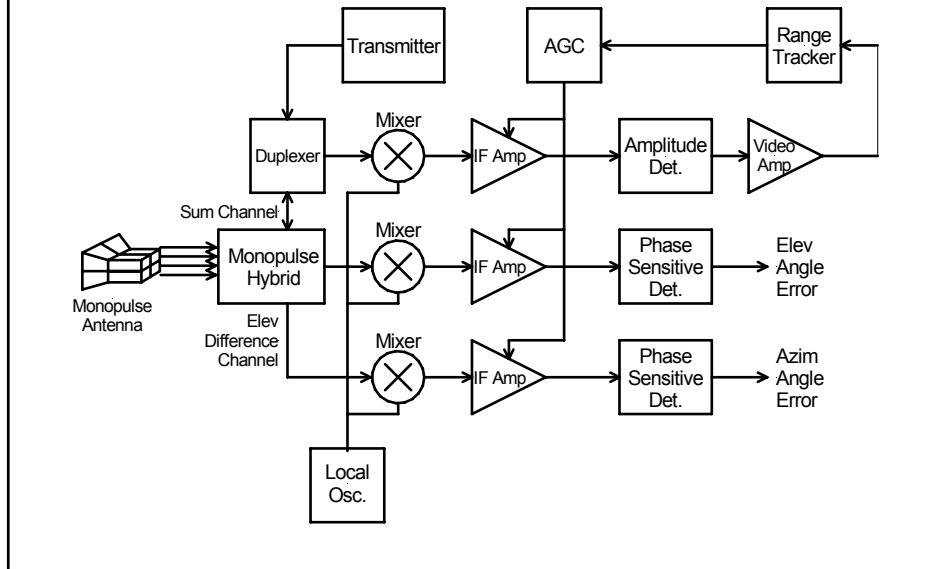

Monopulse Normalisation

- Difference channel IF signals are normalised with respect to the sum channel to produce an error signal that is independent of the echo amplitude
- This ratio can be obtained using an AGC circuit that operates on the two difference channels and is driven by the sum channel, or by division after detection in a digital tracker .
- An **envelope detector** generates the sum channel voltage signal from the sum channel IF
- To obtain angular error signals that include sign and magnitude, **phase sensitive detectors** demodulate the azimuth and elevation error signals using the sum channel IF signal as a reference to produce the two error voltages.

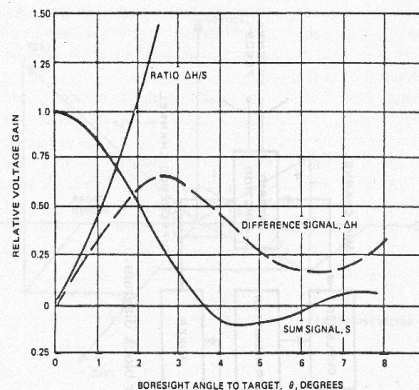

Monopulse Model

- The sum and difference channel voltage signals can be modelled as follows
- Accurate for the main lobe only

$$E_{sum} = \cos^2(1.14\Delta)$$

$$E_{dif} = 0.707 \sin(2.28\Delta)$$

- where E_{sum} – Normalised sum channel output voltage
 E_{dif} – Difference channel output voltage (normalised to sum channel)
 Δ - Angle from the beam axis normalised wrt to the half power sum channel beamwidth

Vehicle Collision Avoidance

- Overlapping multiple beams are used to estimate the angular positions of vehicles

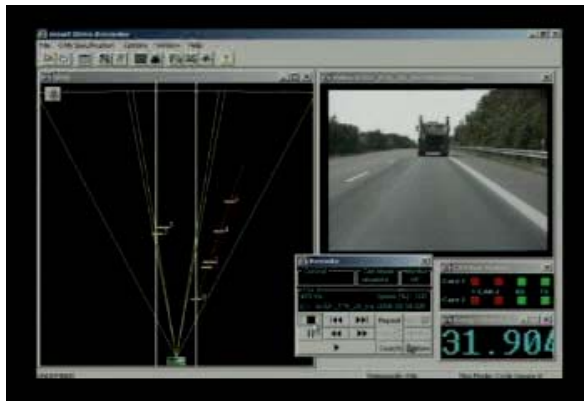

Comparison between Conscan & Monopulse

- Greater S/N for the same size target with monopulse due to the higher on-boresight antenna gain (only the gains of the difference channel signals are reduced)
- Steeper error slope near the origin results in superior tracking accuracy
- Because new tracking information is generated with each new pulse, tracking is not degraded by fluctuations in echo amplitude.

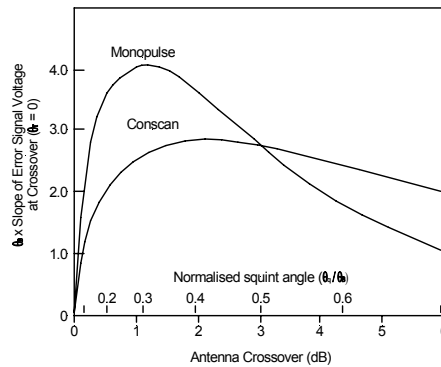

Normalised Error Slope as a Function of Squint Angle

Tracking Accuracy

- Extremely accurate angle measurements can be achieved by null steering the antenna
- For a point target, the theoretical improvement in accuracy in thermal noise is limited only by the signal to noise ratio of the measurement

$$\sigma_t = \frac{\theta_{3dB}}{k\sqrt{2(S/N)}f_r / \beta_n}$$

- where:
- θ_{3dB} – Antenna Beamwidth (deg)
 - k – Constant dependant on the tracking type
 - S/N – Signal to noise ratio
 - f_r – Pulse repetition frequency (Hz)
 - β_n – Angle servo bandwidth (Hz)

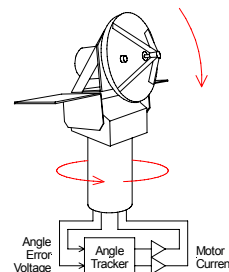

Angle Estimation Applications: Instrument Landing System (ILS)

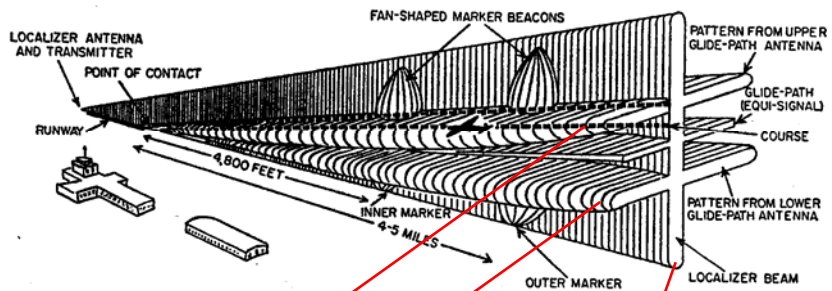

CF 330MHz Mod 90Hz

CF 330MHz Mod 150Hz

CF 110MHz Mod 90/150Hz

Glide angle 2 to 4.5° adjustable

Acoustic Monopulse

The diagram illustrates the Acoustic Monopulse system. It includes:

- Antenna Beam Pattern:** A diagram showing the beam pattern with a **Beacon** and **Receiver** (Right and Left). The beam is split into **Gain Right** and **Gain Left** sections. The **Half squint** angle is also indicated.
- Receiver:** A photograph of the receiver unit, which is a rectangular metal box with two circular ports on the front.
- Graph:** A graph showing the **Error Signal (volts)** versus the **Angle off Boresight (deg)**. The graph displays four curves representing different beam patterns: **15deg**, **10deg**, **5deg**, and **Half squint**. The error signal ranges from -0.8 to 0.8 volts, and the angle ranges from -60 to 60 degrees.
- Internal View:** A photograph of the internal circuitry of the receiver, showing various electronic components and wiring on a printed circuit board.

Triangulation

Triangulation
using Angles

Triangulation
using Range (TOF)

Navigation: GPS, Omega, Loran-C
 Optical Surveying
 Laser Triangulation
 Radio emission detection
 Pinpointing earthquakes

Loran-C Coordinates
 GRI 7980: X, Y, Z
 at
 30:16:28.82 N
 97:44:25.19 W

Peter H. Dajna 9/12/94

MOVING TARGET TRACKING

Tracking Example



Coherent Pulsed Radar

- Coherent radar systems extract both amplitude and phase information from the signal reflected by a target.
- This is required because the length of a single pulse is too short to resolve typical target Doppler frequencies. To extract Doppler shift, the returns from many pulses over an observation time T must be analysed so that the spectrum can be resolved down to a bandwidth $\beta \approx 1/T$.
- For this process to work, a deterministic phase relationship must be maintained over the observation time T .
- Radars capable of maintaining and measuring phase are called Coherent

Typical Doppler Modulation

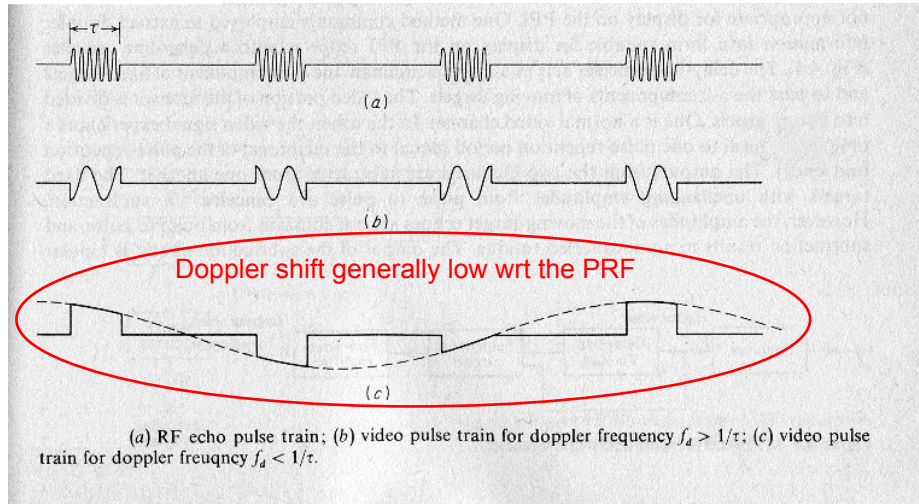

Single Channel MOPA Coherent Radar

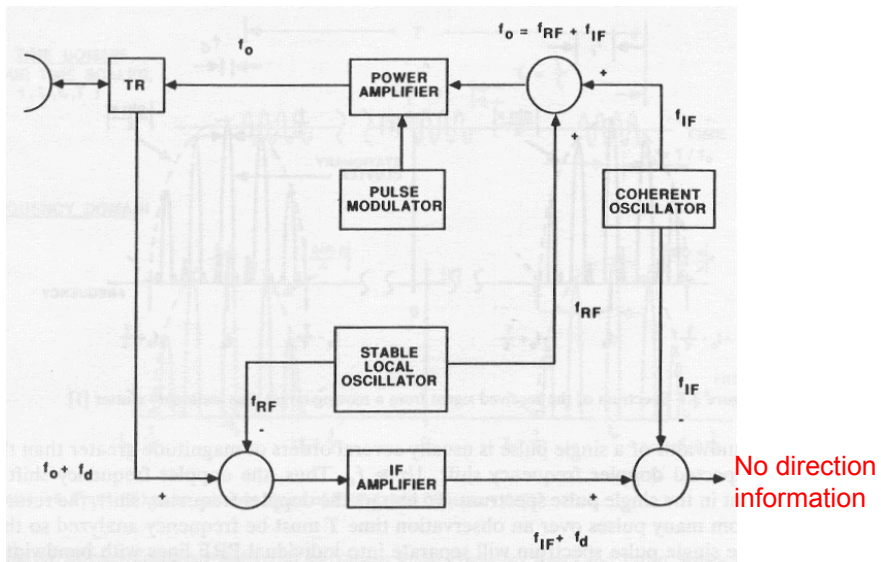

I/Q Coherent Radar

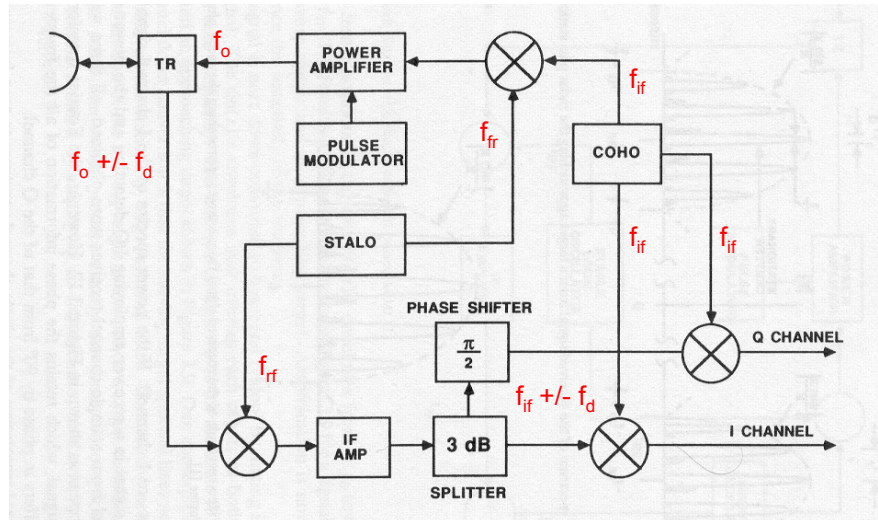

I/Q Detection

- In an I/Q detector, the IF signal is split into two channels with the quadrature (Q) channel being phase shifted by 90° with respect to the in-phase (I) channel
- Though the two Doppler signals output by the I and Q channels will have identical frequency whether the target is approaching or receding, their phase relationship with each other will reverse, and so direction information can be obtained.
- By sampling the I and Q outputs and using a complex fast Fourier Transform (FFT), the magnitude and phase of the combined Doppler spectrum can be obtained.
- Another benefit of I/Q detection over single channel detection is that a 3dB gain in SNR is obtained at the output of the Doppler spectral analysis function.

Moving Target Indicator (MTI)

- If the actual Doppler frequency is not important, but only the fact that the target is moving is important, then a process called Moving Target Indication (MTI) can be applied.
- For a moving target, if the video output of the I or Q channel is examined, the amplitude will vary on a pulse to pulse basis due to the changing phase between the transmitted and received signals.
- For a static target, the phase will remain unchanged, and the amplitude will remain constant.
- An MTI based on a delay-line canceller operates by taking the difference of the amplitudes of successive pulses

Doppler Outputs: Phase Detector

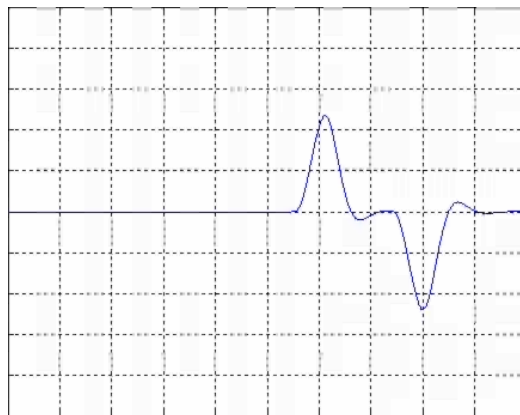

Delay Line Canceller

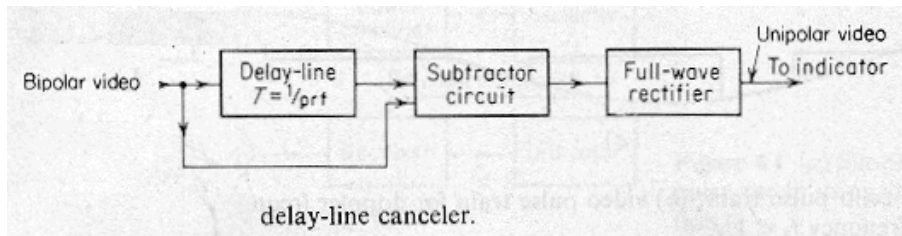
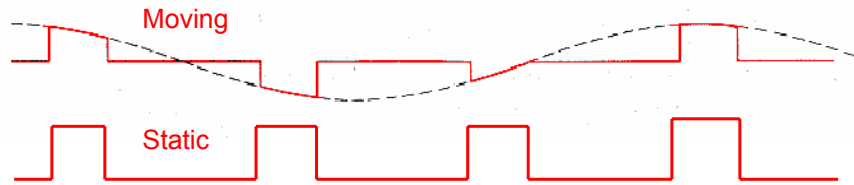

delay-line canceller.

Delay Line Canceller Frequency Response

Finite Element Response FIR Filters
with high-pass characteristics

$$H(z) = 1 - z^{-1}$$

$$H(z) = 1 - 2z^{-1} + z^{-2}$$

Repeated response because
it is a sampled data system

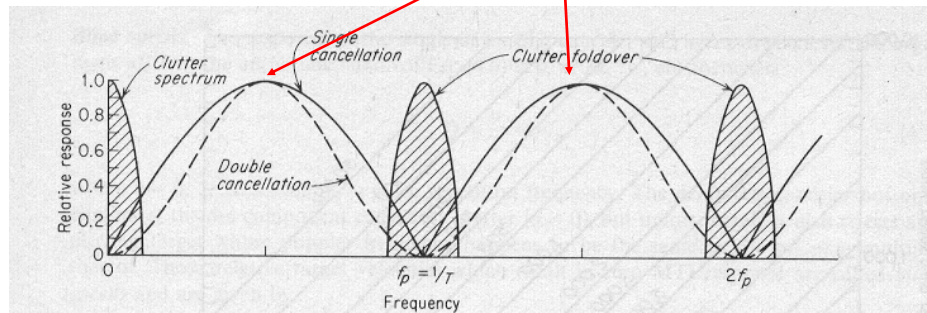

Relative frequency response of the single-delay-line canceller (solid curve) and the double-delay-line canceller (dashed curve). Shaded area represents clutter spectrum.

Blind Speeds

- If the target Doppler frequency lies in the region where $f_d \approx 1/T$, it can be seen that it is attenuated. Zeros also occur at $2/T, 3/T \dots n/T$

$$f_d = \frac{n}{T} = n f_p$$

where f_d – Doppler frequency (Hz)
 f_p – Pulse repetition frequency (PRF) (Hz)

- The actual blind speeds are given by the following formula

$$v_n = \frac{n\lambda}{2T} = \frac{n\lambda f_p}{2}$$

where v_n – Blind speed (m/s)
 λ – Transmitter wavelength (m)
 $n = 1, 2, 3, \dots$

- To obtain a high first blind speed, it is necessary to either operate with a long wavelength (often not practical), or to operate with a high PRF.
- However, a high PRF becomes ambiguous at a short range which is also not ideal for surveillance or long range tracking radar applications.

Staggered PRF

- The effect of blind speeds can be reduced by operating at more than one PRF
- As the ratio of the pulse repetition interval (PRI) T_1/T_2 approaches unity, the greater will be the value of the first blind speed.
- However, the first null also gets deeper and so the rejection of slowly moving clutter will be compromised.

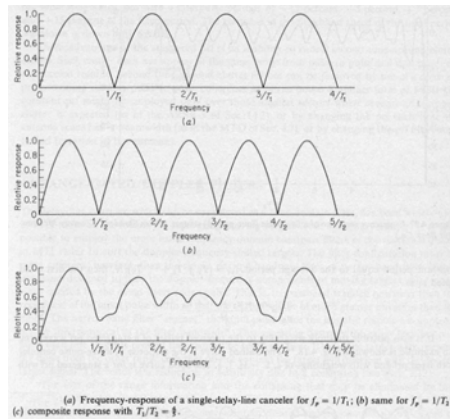

Doppler Filter Bank

- To cater for the moving clutter problem, a bank of Doppler filters can be implemented instead of a delay line canceller. In modern radars, this process is generally implemented digitally using the Complex FFT.
- To obtain sufficient rejection of unwanted signals in adjacent bins, the filter sidelobes must be made as low as possible.

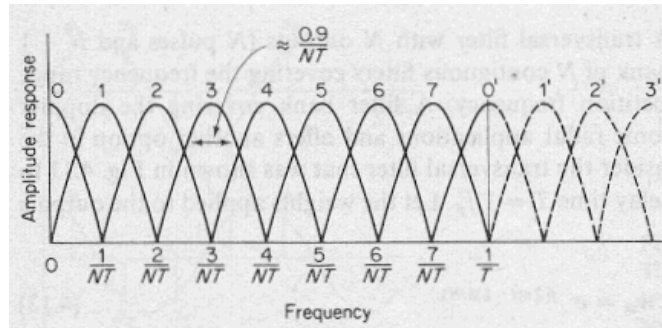

Limitations of MTI Performance

- Sub-clutter visibility is the ratio by which the moving target power may be lower than the clutter in the same range bin, and still be detected with a specified P_d and P_{fa} .
- It is usually limited by internal instabilities in the amplitude and phase of the various waveforms generated by the radar
- It is also limited by the motion of a scanning antenna and the finite time on target which has the effect of widening the clutter spectrum
- Finally, it is limited by the bandwidth characteristics of real clutter. Rain is blown by the wind, the sea moves, as do leaves and grass.

Tracking and Coordinate Frames

■ Measurement Frame

- Radar measurements are made in polar space (R, θ, ϕ) as the radar can only measure range, elevation and bearing (azimuth).

■ Tracking and Estimation Frame

- The equations of motion that govern the profile of a target operate in Cartesian space, (x, y, z) , so it is advantageous to transform the co-ordinate system from polar to Cartesian space.
- Generally this frame of reference will remain centred at the radar
- If more than one sensor may be involved in the tracking function, and these sensors are not co-located (they may be on different platforms that move relative to each other), then an earth centred Cartesian frame is generally used. WG84 is an option

Polar (spherical) to Cartesian (rectangular) Transform

A point P can be located by spherical coordinates (r, θ, ϕ) as well as rectangular coordinates (x, y, z) .

The transformation between those coordinates is

$$\begin{cases} x = r \sin \theta \cos \phi \\ y = r \sin \theta \sin \phi \\ z = r \cos \theta \end{cases}$$

or

$$\begin{cases} r = \sqrt{x^2 + y^2 + z^2} \\ \phi = \tan^{-1}(y/x) \\ \theta = \cos^{-1}(z/\sqrt{x^2 + y^2 + z^2}) \end{cases}$$

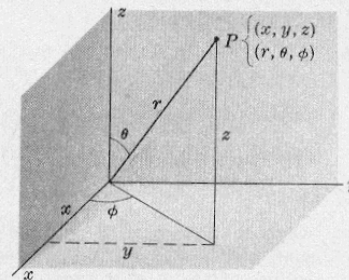

Antenna Mounts

- Selection of antenna mount depends on
 - Type of radar system (surveillance or tracker)
 - Target dynamics
 - Polarisation requirement
 - Base motion rejection requirement
 - Space available

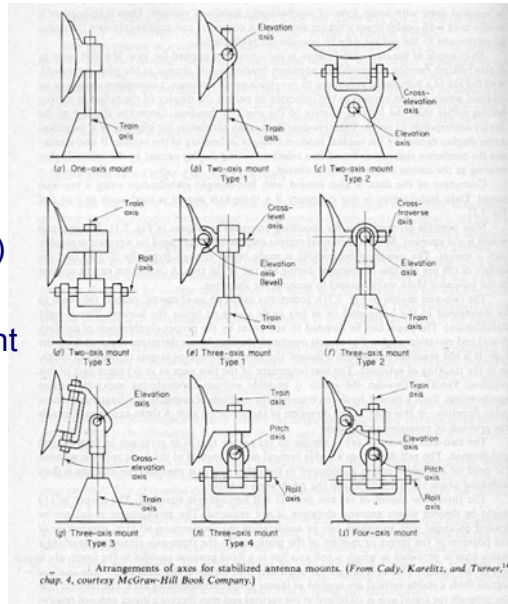

Target Tracking

- The pencil beam of a tracking radar must be pointed at the target
- A typical tracking radar has a 3dB beamwidth between 1° and 2°
- A servo system is used to drive the antenna in the direction that minimises the tracking errors
- Most servo systems are Type II, or zero velocity error systems since, no steady-state error exists for a constant velocity (angular rate) input.
- With Type II systems, dynamic lags proportional to the magnitude of the target acceleration do occur.
- To accommodate this, the tracking bandwidth is adjusted to minimise the tracking error which is due to a combination of measurement noise and dynamic lag.
- At long range where the angular motion of the target is small, a very small tracking bandwidth can be tolerated. However, at short range where target angular rates and accelerations are large, a wider bandwidth becomes acceptable.
- Another restriction on tracking bandwidth is that it must be small (10%) compared to the lowest natural resonant frequency of the antenna and mounting structure to reduce the risk of instabilities occurring.
- Secant correction increases the azimuth error signal gain as a function of elevation angle

Monopulse Tracker

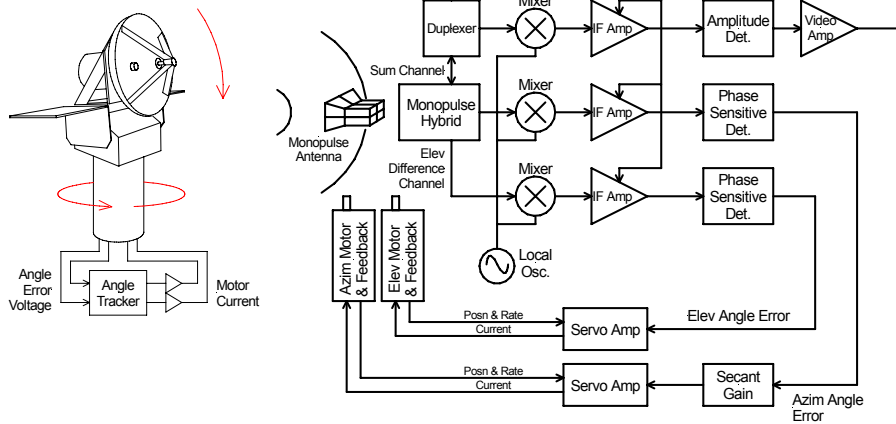

On-Axis Tracking

- The best tracking occurs using null steering when the antenna is pointed towards the target with an accuracy of only a few milliradians. This is known as on-axis tracking.
- It reduces cross coupling between the axes by minimising cross polar levels and reducing the effects of system nonlinearities and increases the on target gain of the antenna
- It requires the following:
 - the removal by prior calibration of biases
 - a filter than can perform one sample ahead prediction
 - the selection of the appropriate co-ordinate system for tracking.
- Target dynamics that dictate the real and apparent acceleration and tracking loop bandwidth determines the tracking accuracy.

Crossing Target and Dynamic Lag

- Conventional servomechanism theory can be used to determine the lag errors in radar tracking loops if conventional loops are implemented.
- The lag error can be written as follows:

$$\delta_a = \frac{\bar{\omega}_a}{K_v} + \frac{\dot{\omega}_a}{K_a} + \frac{\ddot{\omega}_a}{K_3} + \dots$$

- Where the coefficients K_v , K_a and K_3 are the servo error coefficients, the values of which increase with increasing loop gain and bandwidth.
- Servos are classified according to the first coefficient that is finite in the loop design. A type 1 servo has a finite K_v (but infinite position error constant K_0), a type 2 has finite K_a but infinite K_v , etc.

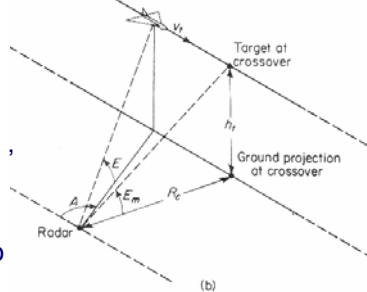
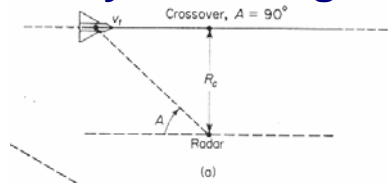

Geometry of the pass-course problem: (a) ground projection of flight path; (b) pass course with target in level flight.

Apparent Range Derivatives

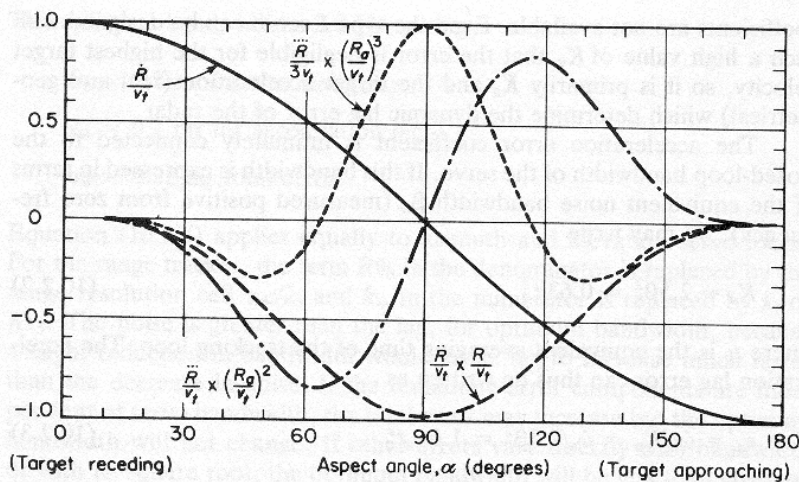

Derivatives of range for pass course.

Tracking in Cartesian Space

- One method of maintaining the noise performance of the system while minimising the dynamic lag is to operate with a wide angle servo bandwidth, but to perform the tracking and smoothing in Cartesian space.
- As there are no geometric accelerations in Cartesian space, it is possible to reduce the filter bandwidth to less than 1Hz. This determines the noise performance of the tracker.
- Because the angle servo bandwidth is wide (typically 10 to 100Hz for a real system), the dynamic lag for geometric accelerations is limited.
- A simplified block diagram showing the loop configuration is shown

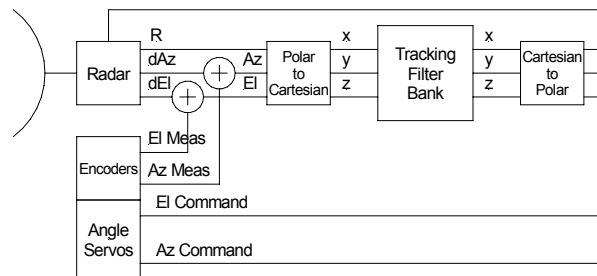

Shipborne Fire Control Radar Design

Ships Motion

- Radar on the deck of a ship 8m above the water
- Roll +/-25° Pitch +/- 10° Yaw +/- 5°
- Period about 5s

Designation

- From a surveillance radar at 1Hz
- Elevation accuracy +/-5°, Azimuth accuracy +/-2°
- Range accuracy +/-25m
- No velocity information

Environment

- Up to sea state 5 (very rough, wave height 2.4 to 3.6m)
- Rainfall up to 25mm/hr

Target Types

- Fixed Wing Aircraft (frontal RCS 1m² independent of frequency)
- Aircraft Height > 60m
- Sea Skimming Missiles (frontal RCS 0.1m² independent of frequency)
- Sea Skimmer height 3m

Detection Performance

- Probability of detection $P_d = 0.95$
- Probability of false alarm $P_{fa} = 10^{-6}$
- Detection time from receipt of designation (excluding slew) 0.5s
- Detection Range (see table)

Requirements continued....

■ Detection Range

Weather	Aircraft	Sea Skimmer
Clear	15km	6km
Rain 12.5mm/h	10km	4km
Rain 25mm/h	5km	2km



Tracking Performance

- Minimum track range $R_{\min} = 50\text{m}$
- Range track accuracy ($<1\text{m RMS}$)
- Angle tracking accuracy ($<1\text{mrad RMS}$)
- Tracking aircraft directly overhead at $h > 100\text{m}$
- Aircraft and missile vel $< 280\text{m/s}$

Safety Constraints

- Average Tx Power $< 100\text{W}$

Polarisation

- For low flying aircraft over the sea we want to minimise the sea clutter
- In calm seas at low grazing angles the difference between the reflectivity for horizontal polarisation and vertical polarisation exceeds 12dB
- As the roughness increases the difference decreases
- The radar will operate using horizontal polarisation, and it will be assumed that the surface reflectivity σ° is -35dB .

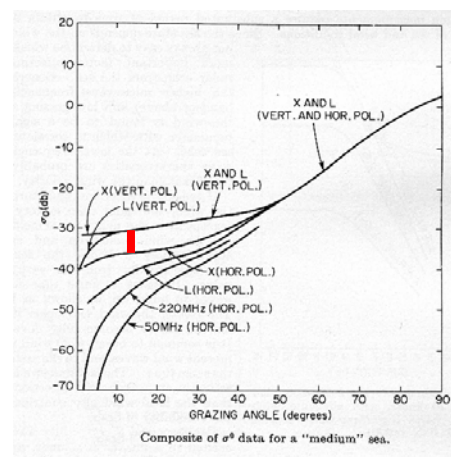

Pedestal

- The maximum combined roll and pitch angle is:

$$\phi_{\max} < \sqrt{25^2 + 5^2}$$

- this does not exceed 30°
- The antenna can be stabilised with respect to this tilt adequately without resorting to a 3rd axis, however, it can result in a significant rotation of the polarisation which may degrade the signal to clutter ratio
- The pedestal will be of the type elevation (θ) over azimuth (ϕ)
 - θ defined as +ve up from the horizontal
 - ϕ defined as +ve anticlockwise from the x-axis
- Minimum tracking angle for a sea skimmer at R=50m ($\theta = -6^\circ$) and a combined roll and pitch angle of 30° requires a minimum angle of -36° ($\theta_{\min} = -40^\circ$).
- To allow the antenna to track over the vertical, and to have time to slew around in azimuth without losing lock at the maximum combined roll and pitch angle requires $\phi_{\max} = 90+30 = 120^\circ$ (use 125°)

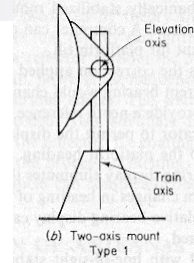

Radar Horizon

- For $h_r = 8\text{m}$ and $h_t = 60\text{m}$, the radar horizon is given by

$$d = 130 \left[\sqrt{h_r (km)} + \sqrt{h_t (km)} \right] = 43km$$

- The radar horizon is not a consideration for this design

Selection of Frequency

- A reasonable maximum diameter for the antenna on a shipboard radar is 1.5m.
- The beamwidth at various frequencies will be as follows:
- A narrow beam decreases the effect of multipath and limits the area of clutter within the tracking gate.
- Attenuation increases with frequency (particularly in the rain)

Frequency (GHz)	Band	Beamwidth (deg)
10	X	1.4
35	Ka	0.4
94	W	0.13

- The minimum elevation angle when tracking at target at $h=60\text{m}$ and $R=15\text{km}$ $\theta = 0.19^\circ$
- The minimum tracking angle when tracking a sea skimmer at $h=3\text{m}$ and $R=50\text{m}$ $\theta = -6^\circ$
- Though it may be possible to minimise the effects of multipath, it is not possible to eliminate them when the radar is looking down at the target.

Multipath Effects

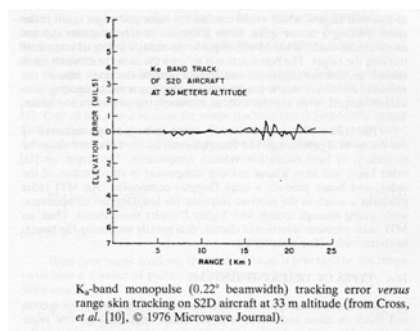
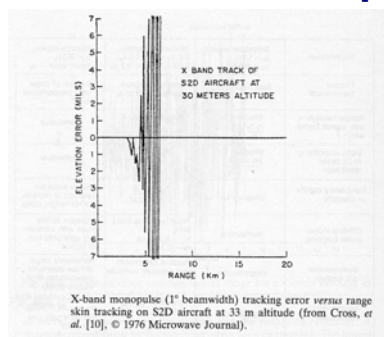

- Use the narrowest beamwidth possible
- Use multipath reduction techniques to achieve an RMS track accuracy of between 0.05 and 0.1 beamwidths
- This excludes the X-band option as a contender with an RMS track accuracy of 2.4mrad (1mrad required)

Adverse Weather Effects

- Typical attenuation at the different frequencies under different conditions is as shown

Band	Clear Air (dB/km)	Rain 12mm/h (dB/km)	Rain 25mm/h (dB/km)
X	0.02	0.25	1
Ka	0.15	3	7
W	0.3	7	12

Single Pulse Signal to Noise ratio

- The required S/N to achieve the specified P_d (0.95) and P_{fa} (10^{-6}) is a function of the target distribution and its fluctuation characteristics.
- For a non-fluctuating target this is 13.6dB.

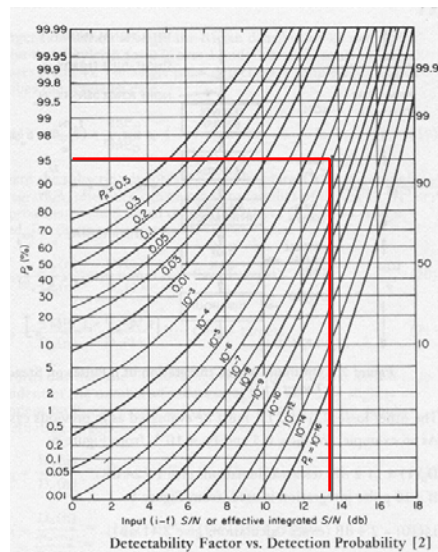

Fluctuating Target

- **Swerling 1:** Many independent scatters of similar RCS. This results in slow fluctuations with time.
- **Swerling 2:** One major scatterer and many smaller scatterers. This is typical of an aircraft nose on. This results in fast fluctuations with time.
- The additional SNR required to achieve these probabilities of the target is fluctuating is determined from this graph. It will be 10.4dB
- The single pulse SNR required is thus $13.6 + 10.4 = 24.0\text{dB}$

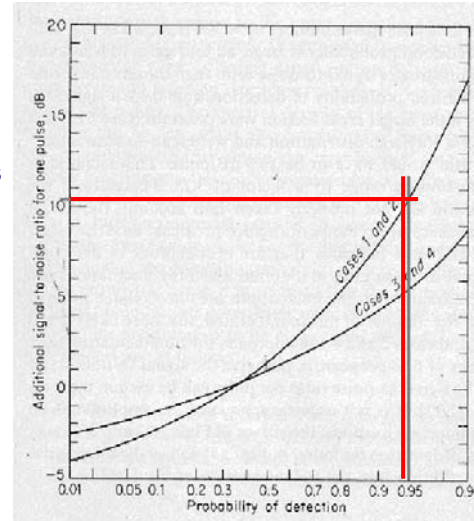

Tracking gate Size

- Ideally, the tracking gate size is matched to the target length
- A typical Jet fighter would be 15m long, so a gate size between 15 and 20m would be ideal. We will use 20m.
- This minimises the amount of clutter received,
- Complicates the target acquisition process as the designation accuracy is only $\pm 25\text{m}$, so at least 3 gates would be required to span the uncertainty



Signal to Clutter Pulsewidth Limited

- At low grazing angles the illuminated area is limited by the transmitted beamwidth rather than the elevation beamwidth
- For a pulse length short compared to the elliptical footprint

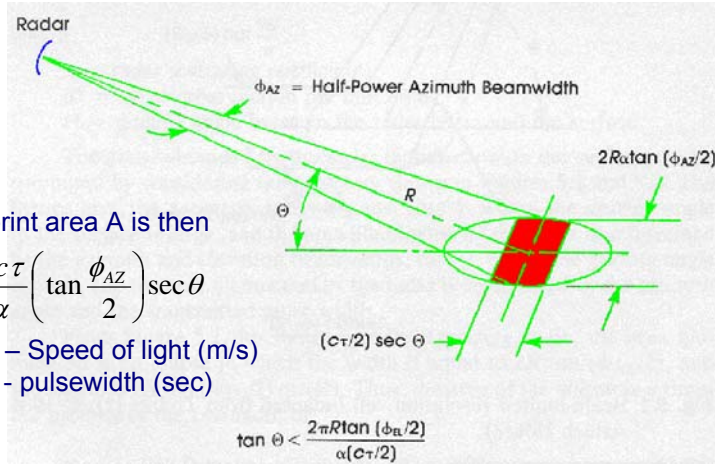

Signal to Clutter

- We assume that the reflectivity of the sea is the same at X, Ka and W bands $\sigma^0 = -35\text{dB}$
- We assume that a similar SCR is required as SNR
- For a gate size of 20m, the illuminated area will be a function of the antenna beamwidth
- For an aircraft RCS of 1m^2 (0dBm^2) or a sea skimmer with an RCS of 0.1m^2 (-10dBm^2), we are looking for an extra 20 to 30dB of signal to achieve the required SCR of 24dB
- Integration improvement cannot be used for improving the SCR because clutter is correlated, so integration will not be as effective.

Band	Beamwidth (deg)	Footprint 6km (m ²)	RCS 6km (dBm ²)	Footprint 15km (m ²)	RCS 15km (dBm ²)
X	1.4	2928	-0.33	7320	3.6
Ka	0.4	840	-5.8	2100	-1.8
W	0.13	264	-10.8	660	-6.8

Sub Clutter Visibility Required

- The primary difference between the targets and the clutter is that generally the target has a significant radial velocity and the clutter is static (or slow moving in high seas).
- Some form of MTI will have to be implemented that can achieve a sub clutter visibility of up to 34dB for a SCR = 24dB

Band	Clutter RCS 6km	Missile RCS	Sub Clutter Vis
X	-0.33 dBm ²	-10 dBm ²	33.6 dB
Ka	-0.58 dBm ²	-10 dBm ²	28.2dB
W	-10.8 dBm ²	-10 dBm ²	23.2dB

Band	Clutter RCS 15km	A/C RCS	Sub Clutter Vis
X	3.6d Bm ²	0 dBm ²	22.6 dB
Ka	-1.8 dBm ²	0 dBm ²	22.2 dB
W	-6.8 dBm ²	0 dBm ²	17.2 dB

Moving Target Detection

- To achieve a sub clutter visibility of up to 34dB the following options are available
- A delay-line canceller, however because the ship will be moving, the clutter will also have an effective velocity, so this is not a good technique to use.
- An better alternative is to take more samples, to window them and to use an FFT to isolate moving from "static" targets.
- With a Hamming window, a static return rejection of 42dB can be obtained. However, it is unlikely that if the measurement is unambiguous in range, that it will be unambiguous in velocity.

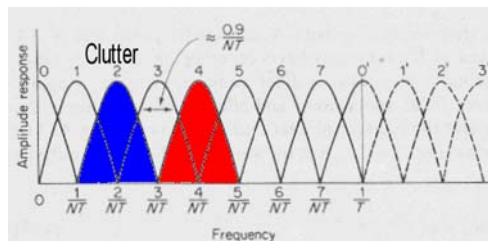

Pulse Repetition Frequency

- To be unambiguous in range out to 15km, the maximum allowed PRF is calculated as follows:

$$PRF = c/2R_{\max} = 10\text{kHz}$$

- This is unambiguous in velocity up to a Doppler frequency of 5kHz
- The maximum unambiguous radial velocity is given by the following formula:

$$v_r = \frac{f_d \lambda}{2} = \frac{PRF \cdot \lambda}{4}$$

- Velocity spread for sea and rain clutter will probably exceed 8m/s which will fill all of the W-Band frequency bins

Band	Unambiguous Velocity (m/s)
X	75
Ka	21.5
W	8

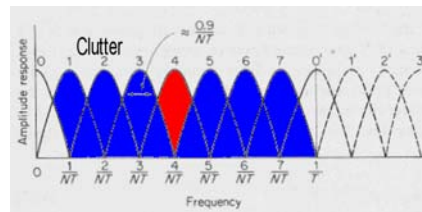

Search Requirement

- Search a volume $10^\circ \times 4^\circ \times 50\text{m}$ in less than 0.5s to meet the specification.
- Option A requires that the pedestal changes direction more often than option B, and there is more of an overlap between scans with option C, so adopt option B
- For a 50% overlap between scans, the total distance that must be travelled to search each area is determined from the number of vertical scans required to cover the 4° in azimuth.
- Insufficient hits to generate FFT at either Ka or W band

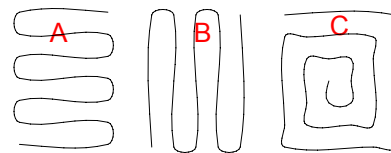

Band	Vertical Scans	Length (deg)	Speed (deg/s)	Hits/Scan
X	5	50	100	140
Ka	15	150	300	13.2
W	46	460	920	1.4

Options

- Reduce the search area
 - Accuracy of designation source must be improved
- Decrease the beam overlap during a scan
 - Decreases the probability of detection or
 - Increases by 3dB the SNR required for detection
- Increase the search time
 - The target may have moved in range so more range gates must be processed
 - The target may have moved in angles so a wider search must be conducted
- Increase the pulse repetition frequency
 - Radar becomes ambiguous in range
 - Multiple PRF's are required to resolve ambiguity

Solution

- Decrease the beam overlap from 50% to 0%

Band	Vertical Scans	Length (deg)	Speed (deg/s)	Hits/Scan
X	3	30	60	233
Ka	10	100	200	20
W	31	310	620	2.1

- Options include using a 16pt FFT at Ka-Band or a 128pt FFT at X-Band
- A total of at least 17 gates will be required to span $50+140+140=330\text{m}$ in range
- The additional angular search requirement is ignored

Integration Gain

- The FFT process is the equivalent of a coherent integrator, which will produce gains of $10\log_{10}(N)$.
- We use the following graph (which is not quite correct as it assumes post detection integration) to accommodate the fluctuation effects
- For a $P_d \approx 0.95$ (we use 0.9) and a Swerling 2 target, the integration gain is about 17dB for the 16 point FFT at Ka band
- For the 128 point FFT at X band, the integration gain is about 24dB

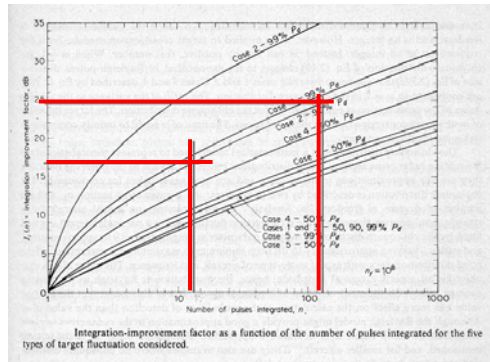

Matched Filter

- We assume that the pulse is rectangular and that the filter is made up of 5 cascaded tuned bandpass sections
- The optimum $\beta \cdot \tau = 0.672$ with a loss in SNR = 0.5dB
- For a pulse width of 20m (133ns), the optimum bandwidth $\beta=5\text{MHz}$

Transmitter Power

- The average power allowed is 100W
- The pulse width is 133ns and the PFR is 10kHz making the duty cycle 0.133%
- The peak transmitted power $P_t = 75\text{kW}$.
- This can be achieved using a Magnetron or Travelling Wave Tube at Ka or X band

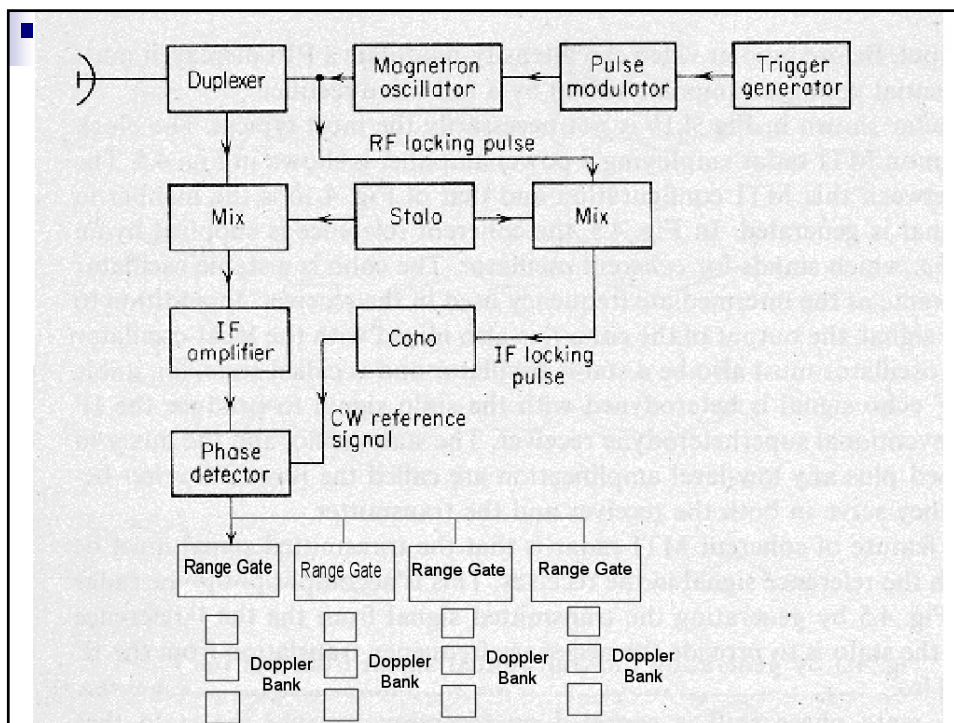
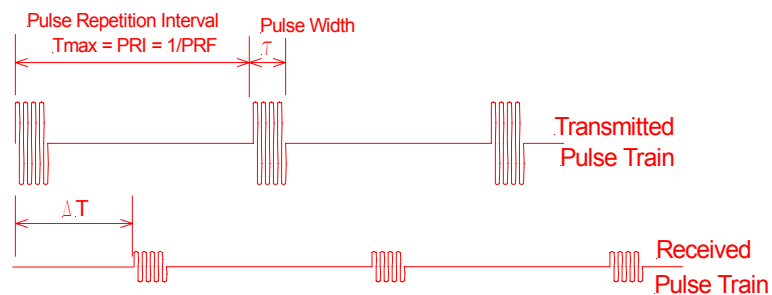

Detection Range at X and Ka Band

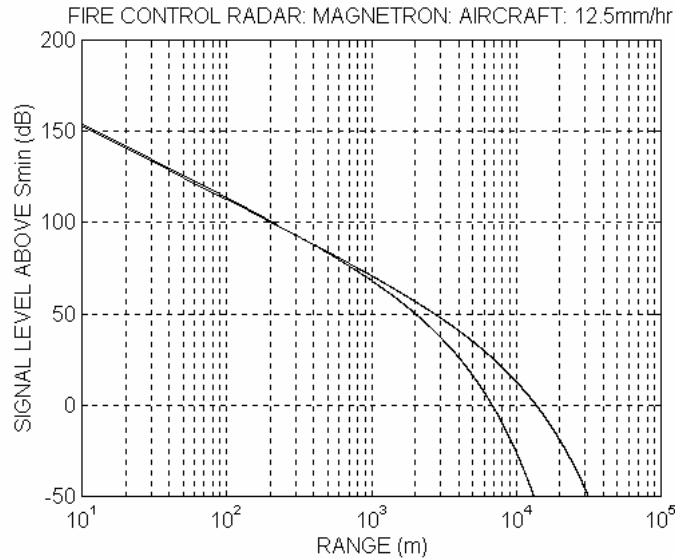

Performance

- For aircraft detection, only the X-Band radar meets the specified range criteria of 15, 10 and 5km
- Both the X-Band and the Ka-Band radars meet the sea skimmer detection requirements of 6,4 and 2km

Target	Condition	X-Band Range (km)	Ka-Band Range (km)
Aircraft RCS=1sqm	Clear	58	37.5
	12.5mm/h	28.9	6.8
	25mm/h	13.7	3.6
Sea Skimmer RCS=0.1sqm	Clear	34.4	25.8
	12.5mm/s	20.6	5.7
	25mm/h	10.8	3.1

Multipath Effect on Detection

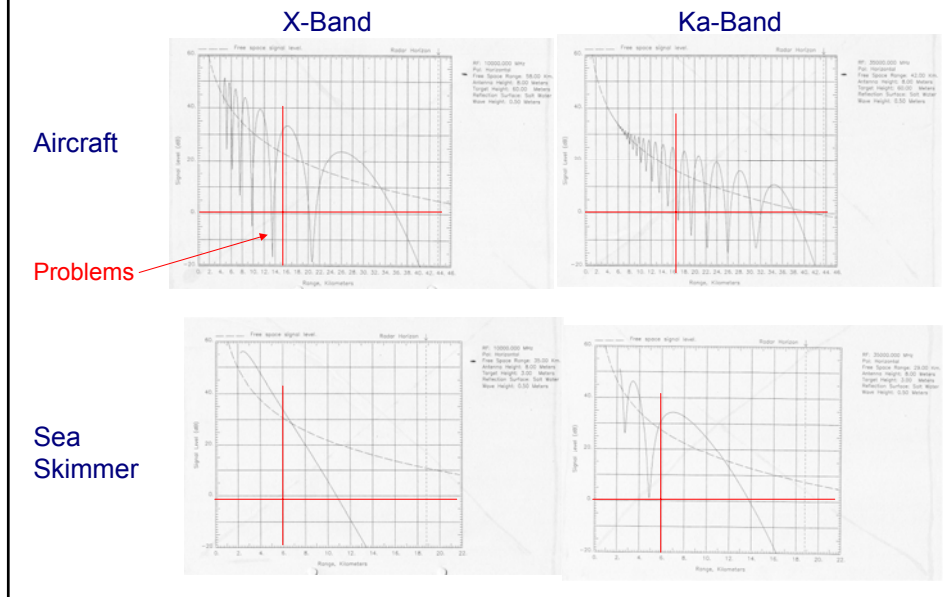

Detection Threshold and CFAR

- The false alarm rate is very sensitive to the setting of the detection threshold voltage.
- Because no velocity information is available, the radar must transmit a block of pulses and look in all the Doppler gates in all of the range gates over the designated range of the target.
- Changes in radar characteristics with time (ageing) and changes in the target background characteristics mean that a fixed detection threshold is not practical. A Constant False Alarm Rate Processor (CFAR) is required
- We propose a cell-averaging CFAR processor that averages the returns from a particular Doppler bin across all of the range gates that span the designated range.

CFAR Processing

- The CFAR averaging process excludes the cell under test which proceeds sequentially from gate 1 to gate N (it is shown in gate 3 in the Figure)

Range gates

D o p p l e r	1	1	2	3	4	5					N
	2	x	x	x	x	x	x	x	x	x	x
	3	x	x	x	x	x	x	x	x	x	x
		x	x	x	x	x	x	x	x	x	x
B i n s	125	x	x	x	x	x	x	x	x	x	x
	126	x	x	x	x	x	x	x	x	x	x
	127	x	x	x	x	x	x	x	x	x	x
	128	x	x	x	x	x	x	x	x	x	x

Transition to Track

- The mechanically operated FCR antenna moving at $60^\circ/s$ (X-Band) or $200^\circ/s$ (Ka-Band) during the search phase is unable to stop while the antenna is still pointing at the target.
- The angles, range and Doppler bin at which detection takes place is recorded as the antenna sweeps past.
- The antenna returns to that designation more slowly
- If the target is not detected, then a slow search is conducted in angles while the range gates broaden their search until a detection occurs or the system times out.
- The angular rates of this new search are such that the antenna can stop while still illuminating the target, and a transition to track mode is made.
- The process of detection involves closing the Doppler loop, followed by the range loop and finally the angle loop

Range Tracking

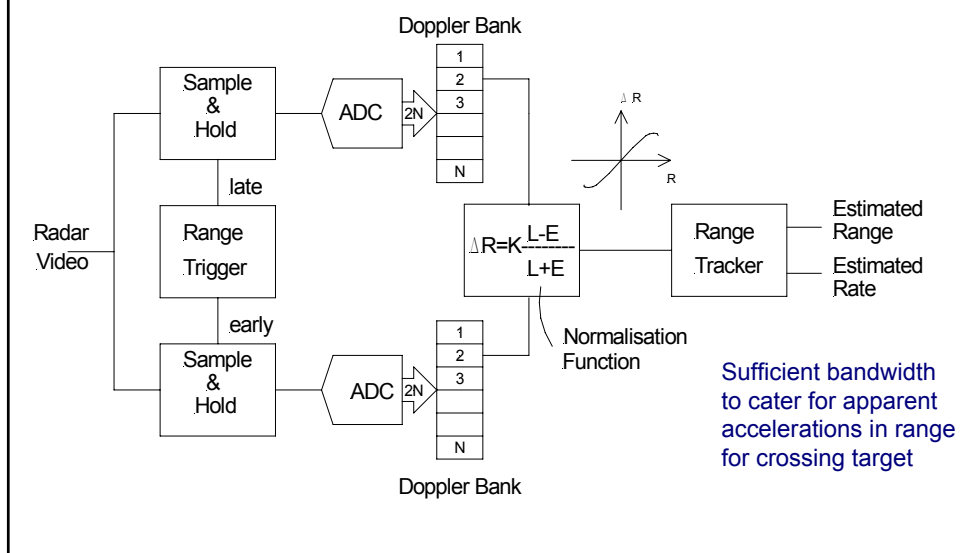

Angle Tracking

- The notes consider tracking in polar space where the optimum servo bandwidths are about 120Hz
 - RMS tracking error, thermal noise 0.36mrad
 - RMS tracking error, dynamic lag 0.41mrad
- An alternative is to use a wide angle servo bandwidth \approx 200Hz to cater for geometric accelerations
- Tracking filters are then operated in Cartesian space with a maximum bandwidth of only 4Hz that will cater for target acceleration induced lags up to 6g

Tracking Configuration

