

TOWER POWER

Tower Light Show Power Supply



Team Members:

Jesse Walson



Jake Wagner

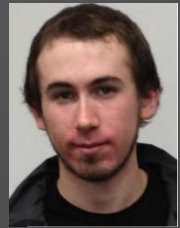

Dave Miller



Team Advisor:
Touraj Assefi



Sponsor:
Robert Rinker

Problem Statement

- ⦿ Since 2010 the University of Idaho ACM has used the Theophilus Tower as a giant pixel display to put on LED light shows.
- ⦿ These shows are accomplished by placing strings of LEDs in the tower windows and controlling them using a laptop, and power them through the Ethernet ports.
- ⦿ The current power supplies bring in roughly 16 volts DC.
- ⦿ The diode strings only require approximately 7.5 V to 10.5 V
- ⦿ Transistors and LED's are over-voltaged causing heat losses and long term damage.

Specifications

- ⦿ 3 power supplies. One for each color LED (Red Green and Blue).
- ⦿ Input voltage for each supply should vary depending on the LED color.
 - Red LEDs drop approximately 2.5 V per diode (7.5 V per string).
 - Blue and green LEDs drop approximately 3.5 V per diode (10.5 V per string).
- ⦿ 270-300 mA of current should be supplied to each of the 40 parallel diode strings.
 - This means a constant current of 12 A for each different color is needed.

Issues to Solve

- ⦿ Load Voltage Much higher than necessary
- ⦿ High voltage on LED's causing damage over time
- ⦿ High voltage over transistors causing power losses and heat generation

Buck Converter

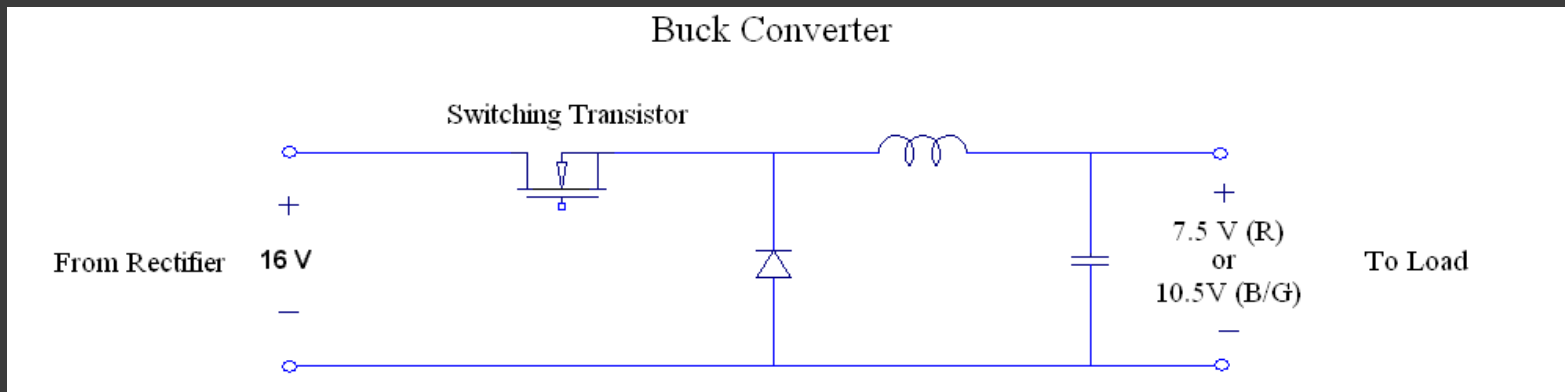

- Using a buck converter will efficiently step down the load voltage to desired levels

Buck Converter Chip

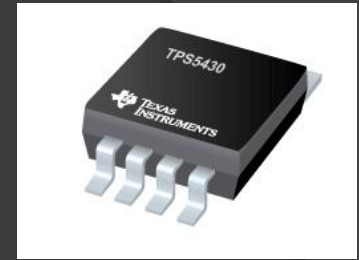

- ◎ 5.5V - 36 V Input Voltage
- ◎ Up to 3A output current
- ◎ 1.22 V - 31 V Output Voltage
- ◎ 500 kHz switching frequency
- ◎ Cost \$2.25 per unit. Potential for free samples
- ◎ Approximately 4 Chips per color
- ◎ 95% efficiency

Buck Converter Application

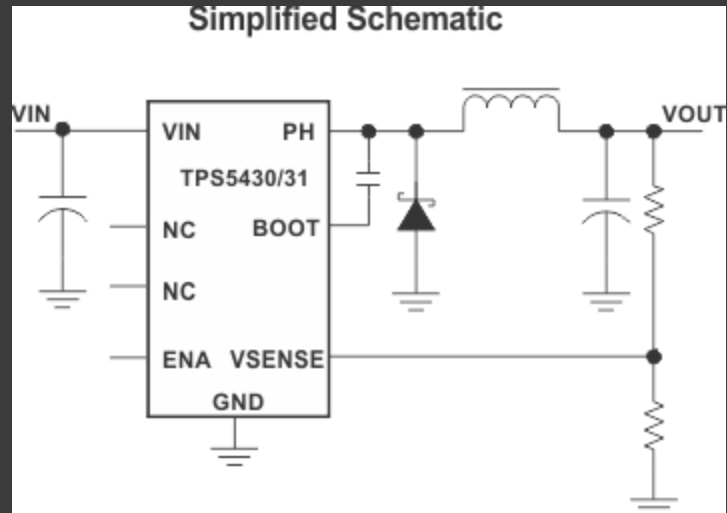

Schematic from TS 5430 Datasheet

- Using buck converter chip and voltage divider, output voltage can be stepped down to necessary levels.
- Voltage is sampled between two resistors
- V_{out} is adjusted until sampled voltage is 1.22 V.

Output Voltage Control Option #1: Potentiometer

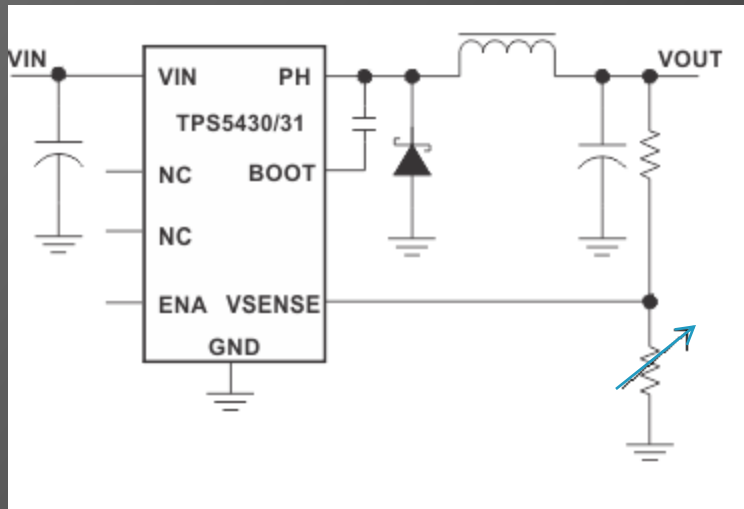

- Place a potentiometer on the sensor feedback voltage divider to control the range of the output voltage.
- Requires a pot for each buck converter, approximately 12 total.

Output Voltage Control Option #2

- A switching mechanism is used to change between set resistors depending on the output voltage.
- Number of possible output voltages would depend on number of switching states.

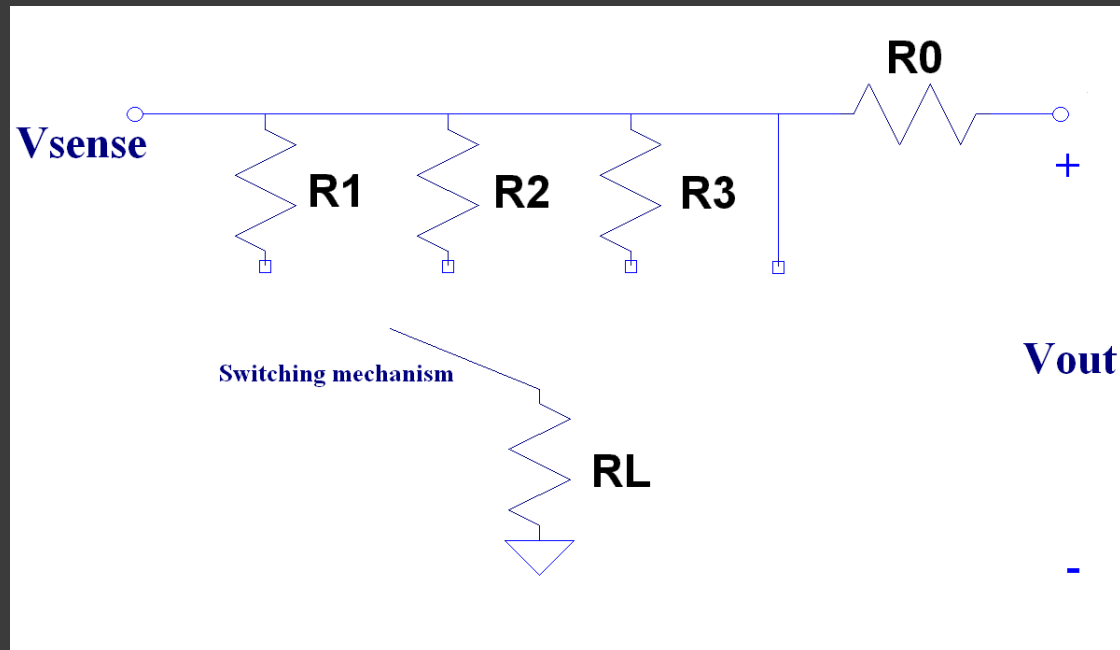

Option #1 Stay the Same

- Three transistors for a constant current circuit
- Transistors require heatsinks due to heat generation
- Been proven to work
- Constant current nearly independent of voltage
- Resistor on base of Q7 determines current

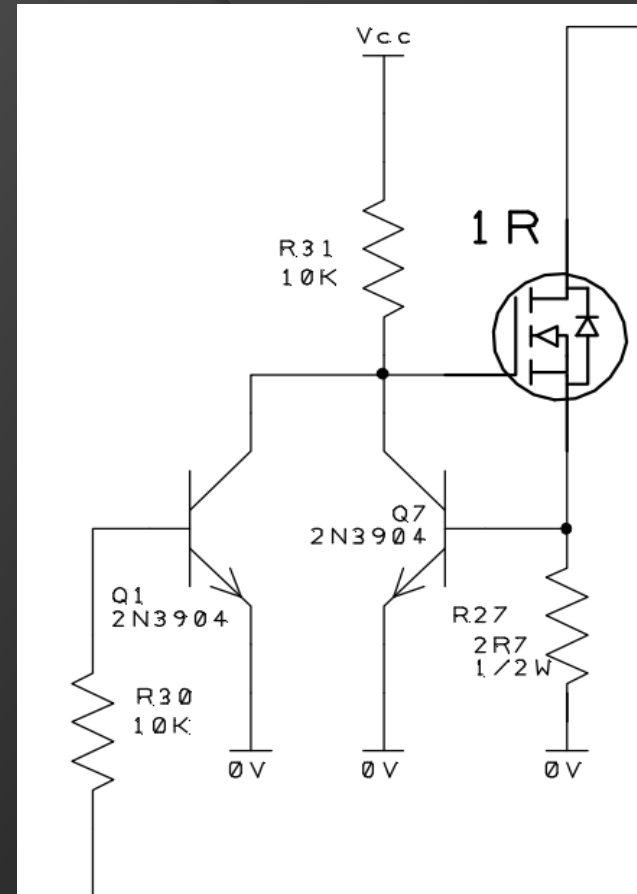

Option #2 Path Switching

- Each channel will have two possible paths
- When LED's are off, an equivalent resistive path will be turned on to maintain current magnitudes
- Increased losses due to resistive path
- Reduced complexity
- Needs precise resistances and design

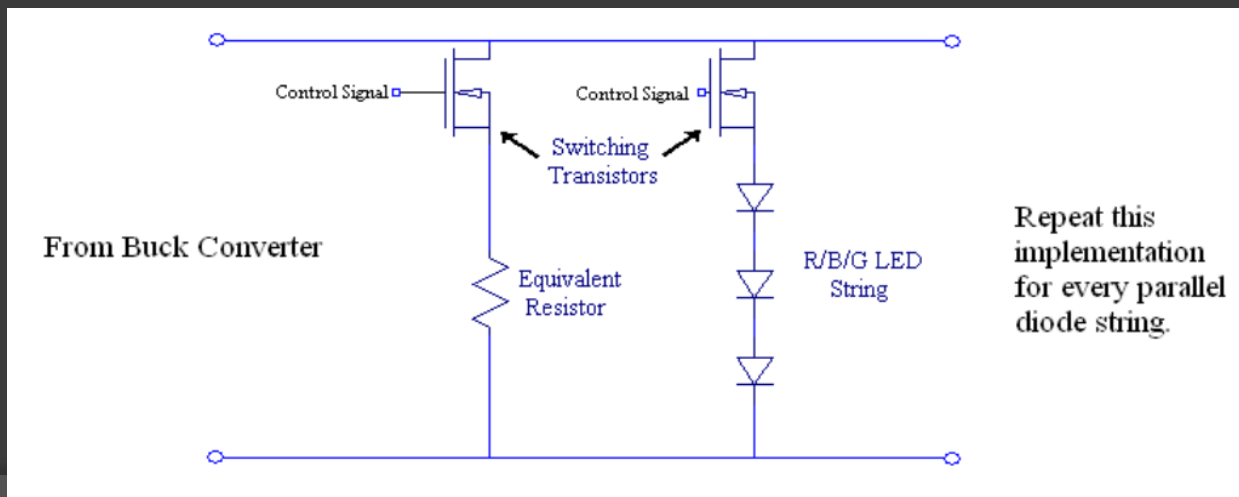

Option #3 Current Regulator

- A current regulating chip allows for the current to be adjusted depending on how many channels are on.
- Control signal will determine the current output
- Eliminates resistive losses that arise in Option #2.
- Greater dynamic control of current output
- Increased complexity of commands
- Possible latency

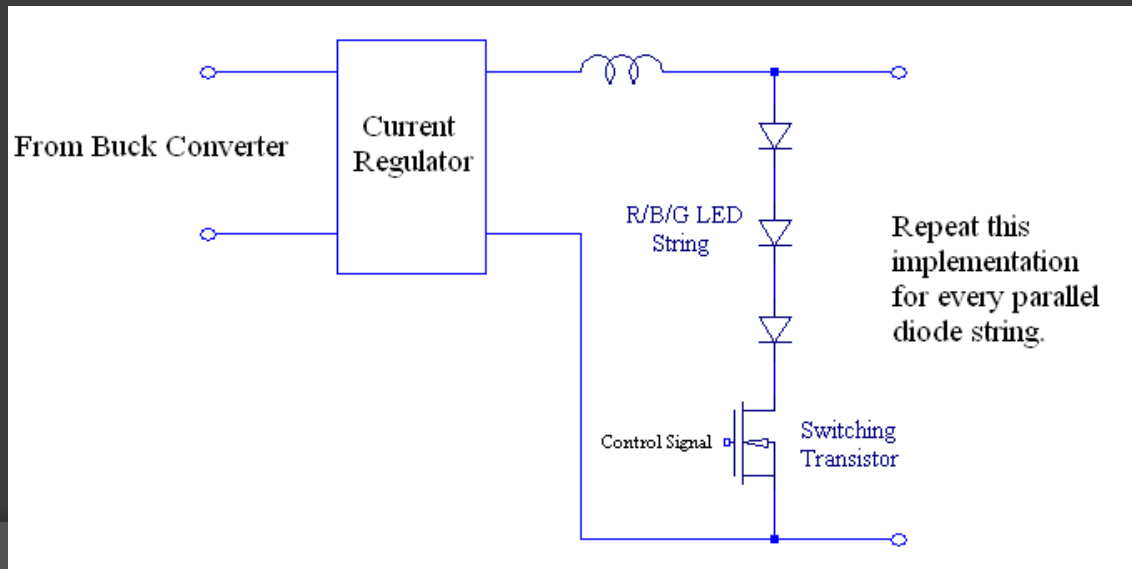

Schedule

- 4/10 – Final design is chosen
- 4/18 – Team member citizenship
- 4/22 – Expo presentation complete
- 4/26 – Expo
- 5/01 – Expectations double check
- 5/03 – All graded materials due
- Fall 2013
 - Testing, Simulation, and Production